

MODEL LPV-3

LONG PATH VISIBILITY TRANSMISSOMETER

TECHNICAL MANUAL FOR
THEORY OF OPERATION AND OPERATING PROCEDURES

 ***OPTEC, Inc.***

OPTICAL AND ELECTRONIC PRODUCTS

sales@optecinc.com
<http://www.optecinc.com>

199 Smith St.
Lowell, MI 49331
U.S.A.
(616) 897-9351
(616) 897-8229 FAX



TRANSMITTER SYSTEM which includes: Light Projector and Control Unit mounted in Environmental Enclosure with Adjustable Base and All-Weather Aluminum Pier .

TABLE OF CONTENTS

Revision 2 – March 2005

| Section | | Page |
|-------------------|--|-------------|
| 1.0 | Introduction | 1 |
| 2.0 | LPV-3 Transmitter - Theory of Operation | 2 |
| 2.1 | Lamp and Lamp Regulation | 2 |
| 2.2 | Projection Optics | 4 |
| 2.3 | Light Beam Modulation | 5 |
| 2.4 | Timed Cycle Mode | 5 |
| 2.5 | Power Supply | 5 |
| 3.0 | LPV-3 Receiver - Theory of Operation | 7 |
| 3.1 | Signal Acquisition | 7 |
| 3.2 | Signal Preprocessing | 9 |
| 3.3 | Signal Processing | 10 |
| 3.4 | Computer Processing | 12 |
| 3.5 | Calculation for Extinction, Visual Range and Standard Dev. | 13 |
| 3.6 | Serial Output Data | 15 |
| 4.0 | Transmitter - Operating Procedures. | 16 |
| 4.1 | The 2-Button Interface | 16 |
| 4.2 | Troubleshooting & Error Codes | 19 |
| 5.0 | Receiver - Operating Procedures | 20 |
| 5.1 | Front Panel Display | 21 |
| 5.2 | 4-Button Interface | 22 |
| 6.0 | Calibration Procedures | 25 |
| 6.1 | ND Filter Method | 25 |
| 6.2 | Differential Path Method | 27 |
| 7.0 | Specifications | 30 |
| 7.1 | General Operating Performance | 30 |
| 7.2 | Transmitter Specifications | 31 |
| 7.3 | Receiver Specifications | 32 |
| Appendices | | |
| A | LPV Calibration Data Sheet | A-1 |
| B | Differential Path Method Derivation | B-1 |
| C | Environmental Enclosure | C-1 |
| D | 13.8 V DC Power Supply | D-1 |
| E | Connector Pin Definitions | E-1 |
| F | Wiring and Circuit Diagrams | F-1 |

LIST OF FIGURES

| <i>Figure</i> | | <i>Page</i> |
|---------------|--|-------------|
| 2-1 | Transmitter Function Diagram | 3 |
| 2-2 | Test Point Voltages | 6 |
| 3-1 | Receiver Function Diagram | 8 |
| 3-2 | Current-to-Voltage Amplifier Configuration | 9 |
| 3-3 | Receiver Signal Processing Waveforms | 11 |
| 3-4 | Example of a Ten Minute Integration | 12 |
| 4-1 | View of Transmitter Control Unit | 17 |
| 4-2 | Transmitter Menu Flow Diagram | 18 |
| 5-1 | Receiver Front Panel Display | 21 |
| 5-2 | Receiver Menu Flow Diagram | 23 |

LIST OF TABLES

| <i>Table</i> | | <i>Page</i> |
|--------------|--|-------------|
| 4-1 | Summary of Transmitter Error Codes | 19 |
| 6-1 | Transmittance for Various Calibration Path Lengths | 26 |

SECTION 1.0

INTRODUCTION

The Model LPV Long Path Visibility Transmissometer consists of a constant output light source transmitter and a computer controlled photometer receiver. The irradiance from the transmitter at a wavelength of 550nm can be measured to a high degree of accuracy both day and night, and over a path length of up to 20 km. Path length is chosen based on the expected extinction values to be measured. A long path of greater than 3 km is used to measure extinction near Rayleigh and a short path of less than 3 km can be used to measure very hazy or foggy conditions. Both the receiver and transmitter operate from a 13.8-volt battery source (12-volt automotive or marine battery) and use 4 and 20 watts of power respectively. The output results can be read as a voltage proportional to extinction or visual range. In addition, a separate serial data interface (COM port) outputs a string of data items in ASCII format that includes all the calculated extinction values, visual range, raw instrument values along with a time stamp. The units can operate for long periods of time unattended in a continuous or timed cycle mode. The self-resetting and backup systems ensure continued operation even after power blackouts or computer lockup. Both units can be synchronized, programmed and calibrated at the home station and installed in the field ready for operation.

The Model LPV-3 Transmitter is an upgraded version of the Model LPV-2 Transmitter, which was discontinued October, 2003. Instead of two units connected by a cable, the LPV-3 transmitter is contained in one unit with only a low voltage power cable needed. An improved user interface using two buttons with a 4-character display allows for easy control over the expanded LPV-3 features.

As of September 2004, the LPV-2 Receiver has been upgraded to the Model LPV-3 Receiver. The large computer control box with thumb switches, rotary switch and analog display has been replaced with a much smaller unit featuring a two-line forty character digital matrix display. All configuration settings are now selectable through a 4-button interface and simple menu system. The LPV-2 Receiver computer controller can be replaced directly with the LPV-3 Receiver controller with no change in cables or operational methods. An improved PC interface allows for complete configuration of the LPV-3 Receiver, testing certain important functions and data logging.

SECTION 2.0

LPV-3 TRANSMITTER - THEORY OF OPERATION

One of the major design requirements of the transmitter projector is that it operate with the low voltage (10.6 to 15 volts DC) and limited power available from batteries with integrated solar cell recharging panels. A modified low voltage tungsten lamp is used with a Koehler illumination projector system to give the equivalent light output of a bare 1500-watt lamp. Figure 2-1 shows a functional diagram of the transmitter projector system. This LPV-3 model is an upgraded version of the LPV-2 transmitter that was designed in the 1980s. The LPV-3 model has the same functions as the LPV-2 but with improved accuracy, lower power and more flexible user interface.

2.1 LAMP AND LAMP REGULATION

A pulse width modulation method is used to power the lamp. Use of this method allows for very little power to be wasted in the lamp drive circuitry thereby extending battery life and reducing heat generated in the projector unit. The LPV-2 transmitter used a linear design which wasted as much power in the control circuit as in the lamp.

The tungsten lamp's nominal effective operating voltage is 6 in the MED setting and it uses 14 watts of power. It is critically pre-focused and centered in a special mounting which allows easy replacement in the field without the need to align the lamp with the optics after lamp replacement. Expected life of the lamp at the MED setting is approximately 500 hours of operation. Lamp output is adjustable by changing the applied power to it, which also affects lamp life greatly. For short working path lengths of 2 to 6 km, the lamp power could be set to the LOW (12 watts of power) setting with the resulting decrease in light output of 50% but an increase in lamp life by a factor of 10. Conversely, setting the lamp power to the HI (16 watts of power) setting will increase lamp output by 40% and decrease life by 70%. Lamp power settings are selected via the 2-button interface. See Fig. 2-2 which shows effective lamp voltage vs. lamp power.

As the lamp ages, the applied power will increase to keep the output constant. When the system detects that the power has exceeded its upper limits, an ER=2 will be displayed on the DRO indicating the need for lamp replacement. In addition, the unit will shut down the lamp and chopper.

To maintain the lamp output constant at better than 1%, an optical feedback method is used. The feedback detector views an area of the chopper that interrupts the beam going to the projector optics. The chopper is coated with a flat white diffuse surface which scatters light very effectively. A narrow band filter with a center wavelength of 550 nm and bandwidth of 10 nm is mounted in front of the detector so that only this wavelength is measured and regulated. A pre-amp configured as a current-to-voltage amplifier converts the photocurrent from the detector to a

voltage which is fed to the 10-bit A/D converter port of the PIC microcontroller. From there, the measured output from the lamp is compared in preset values for the LOW, MED and HI settings and the output to the lamp drive circuit is altered accordingly.

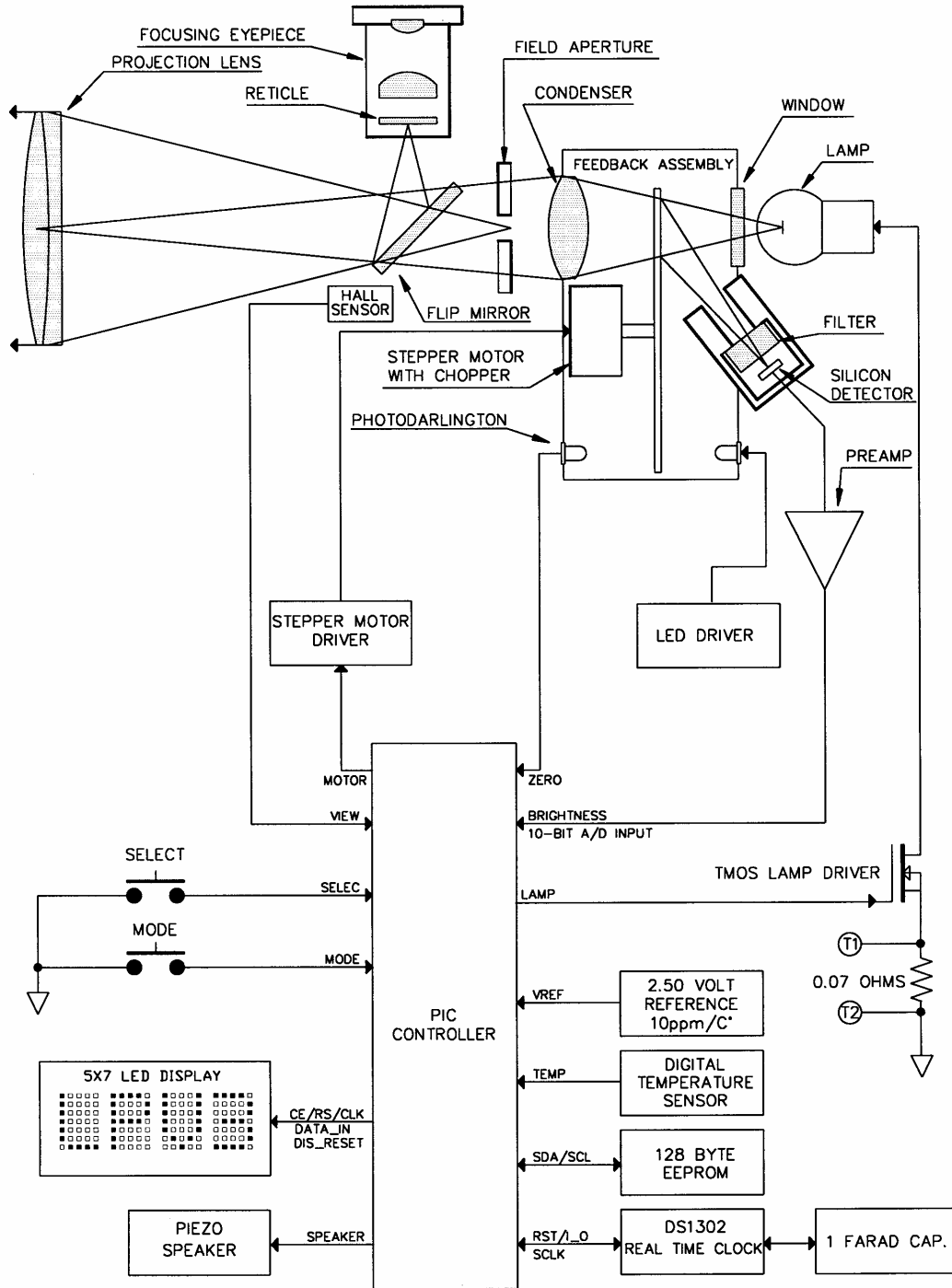

Figure 2-1. Transmitter Function Diagram.

Since dust and evaporated films could affect the transmission of the feedback optics causing the output of the lamp to increase by some unknown amount, the optics and coated chopper blade are enclosed in a sealed block. The front surface of the condenser lens and both sides of the projector lens are the only surfaces which need to be cleaned on a routine basis.

2.2 PROJECTION OPTICS

To increase the output from the low power lamp to a level necessary to be measured accurately by the receiver, a Koehler projection system has been used in the transmitter. Use of this method increases the output of the lamp in a 1-degree diameter cone by a factor of approximately 100 without degrading the isotropy of the beam appreciably over an angular diameter sufficiently large to negate the effect of beam spread due to turbulence. Simply stated, the condenser collects the light contained in a solid angle of 11 degrees as seen from the filament and, with the projector lens, concentrates this light into a 1-degree cone. The 1-degree cone is set by a field aperture at the focus of the projector lens which is also mounted very close to the condenser lens. The condenser lens images the lamp filament on the plane of the projection lens. Proper operation requires that the filament image on the projection lens be entirely contained within its aperture.

The beam isotropy is dependent on the uniform illumination of the field aperture near the condenser lens. Because of shading within the coiled filament of the lamp (rear coils are shaded by the front coils), some non-uniformity is present. Experimental laboratory measurements made on a number of lamps has shown that the maximum non-uniformity to be expected is around 5% and varies smoothly across the 1-degree cone. Within the 0.17-degree cone observed by the feedback detector, less than 1% variation has been measured. Experiments to measure the effects of beam diameter and turbulence on receiver output were made at the Grand Canyon. The results show no measurable change even with beam diameters narrowed to 0.17 degrees in moderately high turbulence conditions. The working path length was approximately 16 km.

To properly point the transmitter projector at the receiver, an eyepiece with reticle can be inserted into the optical path at the focus of the projection lens with the use of hand operated first surface mirror. With the mirror in the down position, a 2.3-degree diameter image of the field is viewed at 14-power. The eyepiece and projection lens are preset for infinity focus but can be adjusted through a small range. NOTE: Any change in the focus position must occur before calibration and operation.

To aid in pointing, a reticle is mounted at the field aperture plane of the focusing eyepiece. Two rings which coincide with the 1-degree total cone diameter and 0.17-degree detector feedback diameter are etched on the reticle. For the most stable transmitter output (no more than 1% variation even with lamp changes), the receiver should always be sighted within the 0.17-degree ring.

2.3 LIGHT BEAM MODULATION

A four-blade chopper mounted near the condenser lens modulates the beam at exactly 78.125 Hz. Modulation of the beam and synchronous detection by the receiver allows the transmitter signal to be separated from background noise. The chopper is rotated at the exact speed of 19.53125 revolutions per second by a low voltage stepper motor. To ensure reliable startup of the motor, the drive pulses are slowly ramped up to the proper frequency before locking onto the set frequency of 78.125 Hz. It takes about 12 seconds for the motor to achieve its final frequency, at which time the lamp will turn on.

2.4 TIMED CYCLE MODE

To conserve power and lamp life, both the chopper and lamp can be powered up in a timed cycle mode. The possible cycle times (period between lamp and chopper turn on) are 20 minutes, and 1, 2, and 4 hours. Cycle times are selected via the 2-button interface using the CYCL menu selection. The length of time the chopper and lamp will run (integration time) at the start of each new cycle is selectable between 2, 16, 32 and 64 minutes. These times are selected using the INTG menu selection. It is also possible to run the lamp and chopper continuously by setting the cycle time to CONT (continuous) in the CYCL menu selection.

When a new cycle starts, the chopper motor is turned on first and the lamp second. The power to the lamp is increased gradually over a period of about 3 seconds to reduce the inrush current surge and thermal shock to the lamp filament. An inrush current surge from turning the lamp on abruptly could exceed 15 amps. Depending on the external battery and associated regulation, this current surge could cause the battery voltage to drop momentarily resulting in any of the following: loss of circuit voltage regulation causing unpredictable effects, activation of the low voltage comparator causing the circuit to shut down and possible detrimental voltage drops to other external instruments connected to the same battery supply. The slow turn-on also extends lamp life by minimizing the thermal shock to the filament.

From the start of the cycle time, it takes approximately 15 seconds for both the lamp and chopper to reach stable operating levels.

2.5 POWER SUPPLY

The input battery voltage can range from 10.6 to 15 volts DC. If the voltage drops 10.5, an ER=1 is displayed on the DRO and the unit will shut down. Internally, this voltage is converted and regulated to +6.0 and -6.0 volts for the analog control portions of the circuit and +5.0 volts for the digital portion. The power circuits, lamp and chopper motor use the power from the battery supply directly. In an idle state with both lamp and chopper motor off, the control

circuit typically uses 10 ma and, when fully on, uses 1.7 amps with a 13.8 volt battery power supply.

In case of battery power interruption, the DS1302 cycle and integration timer continues running by using an on-board power backup consisting of a 1 Farad capacitor. At an ambient temperature of around 25 degrees Celsius, this capacitor will provide enough power for approximately 45 days of operation. An ER=4 error code on the DRO indicates that the timer needs to be reset. This condition is usually due to the no charge on the capacitor. When adequate 12-volt battery power is available, the capacitor is charged back to full capacity in a few hours.

With the lamp on and the unit housed in an air tight environmental chamber in a warm climate, the critical electronic circuitry could possibly get hot enough to potentially cause circuit failure. To prevent this, an onboard temperature sensor monitors the operating temperature of the air around the main circuit board. At 45° C the microcomputer will not initiate a cycle and will wait until the temperature cools. Of course, this protective feature is not available if the unit is working in the continuous mode.

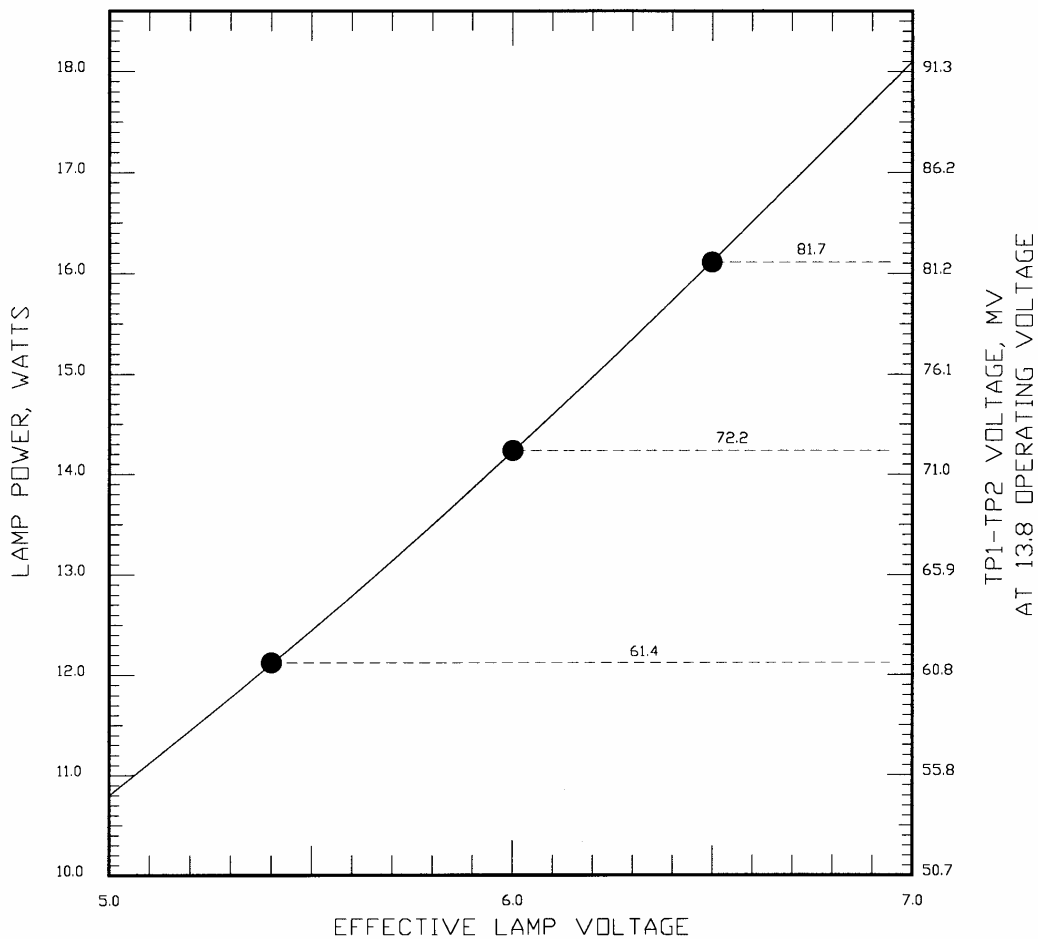

Figure 2-2. Test Point Voltages.

SECTION 3.0

LPV-3 RECEIVER - THEORY OF OPERATION

The LPV receiver uses a very sophisticated and accurate method to retrieve the transmitter signal from amplifier, background and turbulence noise. Simply stated, the modulated signal from the transmitter is locked onto and a small portion of the signal is sampled with the transmitter lamp off and is subtracted from the signal when the lamp is on for each cycle. This difference is integrated over many thousands of cycles, which reduces the combined noise sources to a value much less than the signal of interest. Having stated the method, the problem is then a matter of mere implementation.

3.1 SIGNAL ACQUISITION

A 63mm refractor lens (clear aperture of 58 mm) with a focal length of 350mm, is used to optically amplify the light from the transmitter and provide some smoothing of the signal noise caused by atmospheric turbulence. For very long paths great than 7km, an optional 100mm f/6 telescope is available for increasing signal strength. The refractor lens and photometer head are rigidly mounted in a heavy walled tube which maintains the precise alignment needed to keep the transmitter image centered on the detector.

Light from the transmitter when entering the photometer head is directed either to the focusing eyepiece or the detector by means of a flip-mirror. The focusing eyepiece consists of a 25 mm focal length Ramsden eyepiece and a reticle with a precisely etched ring that determines the detector field of view. After the transmitter light is centered in the ring, the flip mirror is turned to expose the detector. Directly in front of the detector is a narrow band filter with a center wavelength of 550 nm, a bandwidth of 10 nm and a peak transmission of 60%, which is identical to the filter used in the lamp feedback system for the transmitter. For calibration purposes, a neutral density filter with a transmission of approximately 1% can be inserted in the photometer body just in front of the detector.

The detector is a sensitive silicon photodiode operating in the photovoltaic mode with a very low bias current (0.1 pa) electrometer amplifier operating in a current-to-voltage amplifier configuration as shown in Figure 3-2. Photocurrent from the detector (I_s) is balanced by an equal current in the feedback resistor (R_f), but flowing in the opposite direction so that the inverting input is kept near zero potential. The output voltage is thus:

$$E_{out} = R_f \times I_s$$

where R_f is equal to 4000M (4×10^{10}) ohms.

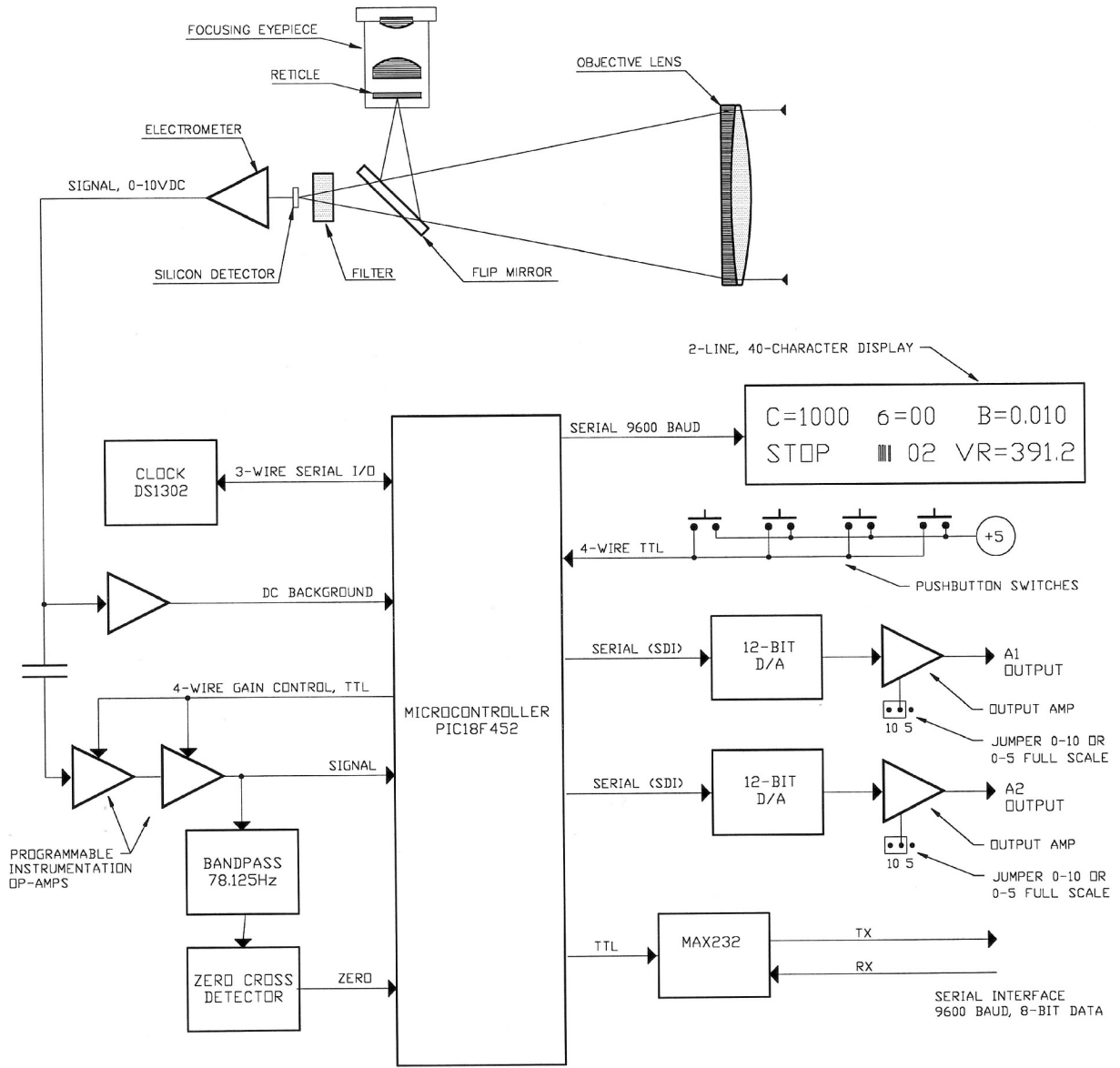

Figure 3-1. Receiver Function Diagram

E_{out} from the photometer head is dependent on detector response, filter/telescope transmission, electrometer gain, output from the transmitter, path length and, of course, atmospheric transmission. The approximate value of E_{out} for a path length of 5 km and extinction of 0.02 km^{-1} is around 25 mv p-p.

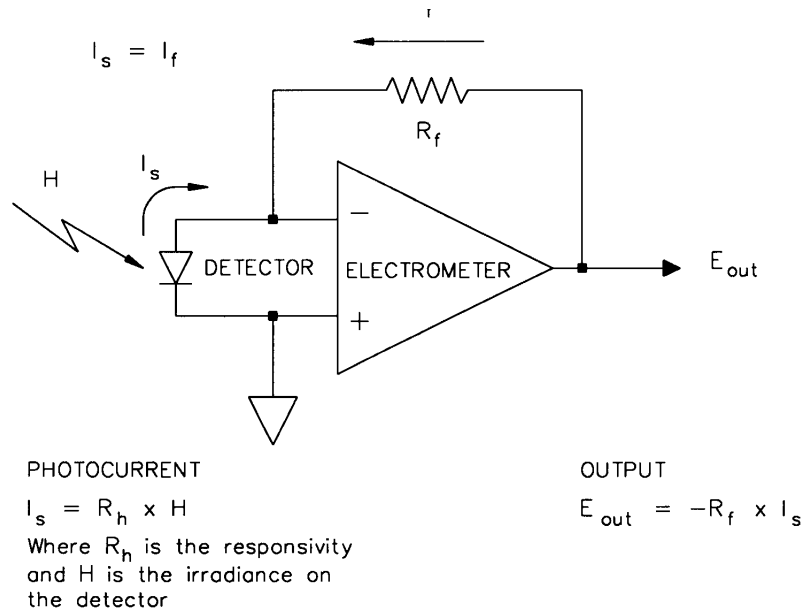

Figure 3-2. Current-to-Voltage Amplifier Configuration

The 1mm x 1mm square detector surface is masked with 0.75mm diameter circular aperture which coincides to the etched ring of the reticle. Since alignment of the detector aperture and reticle ring is extremely important, the electrometer- detector combination is rigidly mounted on a X-Y adjustable bracket centered in the photometer head housing by 4 setscrews located around the circumference of the bracket. Accurate adjustment of this bracket on an optical bench by loosening and tightening opposing setscrews ensures that the detector aperture aligns with the etched ring of the reticle to a centering error of less than 0.001 inch.

3.2 SIGNAL PREPROCESSING

Before digitizing and processing by the computer, the AC signal from the photometer head is scaled by a combination of two programmable gain instrumentation amplifiers (model PGA205) connected in series. The gain is software selectable by factors of two starting with a minimum gain of 1. The other selectable gain values are 2, 4, 8, 16, 32 and 64. The specified typical gain error for each amplifier is $\pm 0.010\%$ and the maximum gain error over the operating temperature is $\pm 0.024\%$.

The signal is scaled to achieve the highest reading value without causing saturation of the A/D converter input. Since atmospheric turbulence can cause extreme momentary fluctuations of the

signal strength, this scaling is usually done during times of peak turbulence. If the AC input peak-to-peak signal exceeds the 0 to 5.000 volt range of the A/D converter, a buzzer will sound for each instance. The rate of buzzing is an indication of the degree of saturation. Adjusting the gain to a lower value would prevent this error condition from occurring.

The DC saturation level for the detector pre-amplifier is approximately 10 volts. This voltage can be reached if the background illumination is sufficiently intense due to the Sun reflecting off snow, water or even bright rocks. If this happens, the signal is lost (zero signal level) and an erroneous extinction value is computed. The intense illumination from the reflected sun will not harm either the detector or pre-amplifier unless the Sun itself is directly in the view. Try to avoid this condition since damage to the narrow bandpass filter could occur.

This background DC level is sampled before the reading is started. If the DC level exceeds 8.00 volts, the reading is paused until the DC level falls below 8.00 volts. An error code of ER=2 is displayed and transmitted on the serial output indicating that the DC background threshold has been exceeded. Once the DC level is below 8.00 volts, the operating program will be restarted.

A part of this signal is used to find the time when the transmitter chopper is open (lamp-on) or closed (lamp-off). A digital bandpass amplifier (LMF100) with a Q of 100 and center frequency of 78.1250 Hz allows the fundamental frequency of the chopped signal to pass to the zero-cross detector. The positive half of the bandpass output (lamp-on) results in the zero cross detector going positive and the negative half (lamp-off) causes the bandpass to go negative with a very fast transition at the zero voltage points. See Figure 3-3. A small amount of voltage hysteresis built into the comparator prevents several pulses of very short duration from being generated during the crossing of the zero point due to signal noise which is not completely eliminated by the bandpass amplifier.

3.3 SIGNAL PROCESSING

In the absence of noise, the difference between the signal level at the top of the wave when the lamp is on and the bottom of the wave when the lamp is off would give an accurate measurement of the transmitter irradiance. Since noise due to the atmosphere and receiver electronics is always present and usually several orders of magnitude greater than the signal, the average difference must be calculated over many thousands of cycles.

In order to extract the signal from the background noise, the receiver must be able to determine precisely the phase of the incoming signal. This is done by locking into the fundamental chopping frequency of 78.1250 Hz by use of a digital bandpass filter with a high Q of 100 followed by a zero cross detector circuit. There is still considerable amount of phase jitter after this stage which is smoothed out by using a phase lock loop circuit. The final square wave output of the phase locked loop with exact 50% duty cycle is now precisely in phase with the chopped signal. This signal is then used by the computer to determine the time to sample the signal.

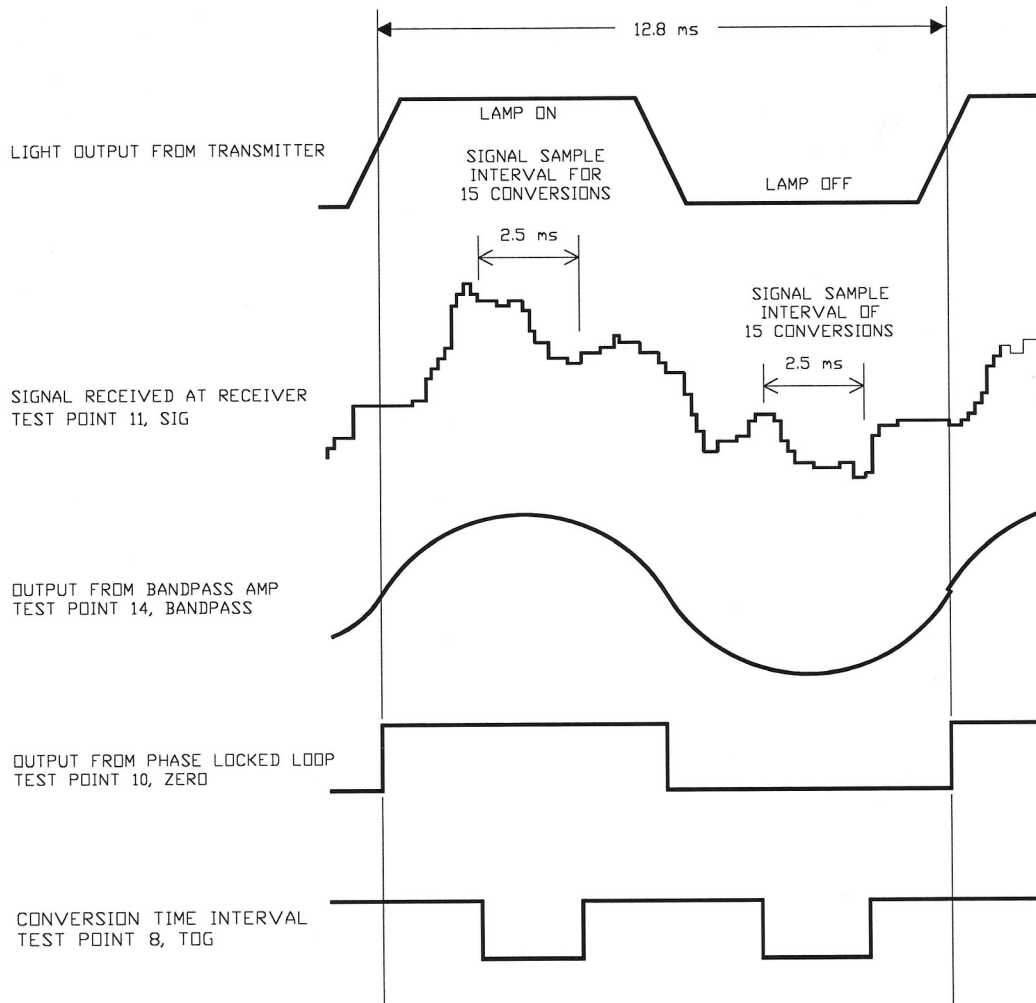

Figure 3-3. Receiver Signal Processing Waveforms

Usually, an integration time much longer than 60 seconds is needed to smooth out the effects of turbulence. The computer will use these 60-second intervals to compute longer integration times. For example: If a 10-minute integration time was selected, then ten 60-second measuring intervals would be used to compute an average value for the reading. See figure 3-4. In addition, the standard deviation of the raw instrument counts for the ten 1-minute integrations is computed and, if selected, sent to the analog channel A2. The practical significance of the standard deviation output is for a check on the quality of data. A large value would indicate unstable seeing conditions such as those produced by rain squalls and smoke. A small value would mean "good data".

A ten minute reading is the average of 10 one minute readings

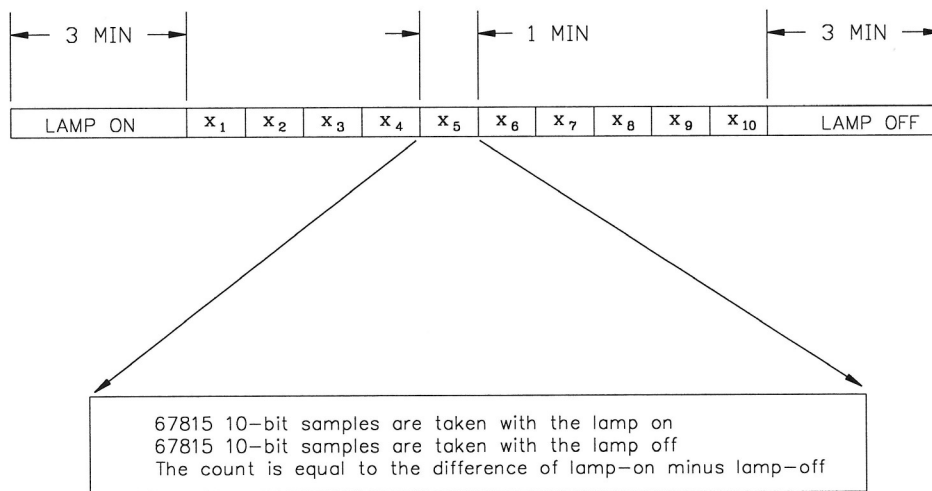

Figure 3-4. Example of a Ten-Minute Integration

3.4 COMPUTER PROCESSING

The computer can process and output the data as count, extinction and visual range. The count is the raw instrument values as internally derived from the A/D conversions and has no units. The count divided by the lamp calibration number is the transmittance of the air path. All three values are sent to the serial output data line and any one of them can be sent to the analog output channel, A1. In addition, the raw instrument value for each 1 minute integration or population standard deviation based on readings that are comprised of two or more one-minute integrations are available on a separate analog output channel, A2. The outputs of A1 and A2 have a full scale range of 10 or 5 volts which are selectable by jumpers on the main circuit board. The outputs have 12-bit resolution and are protected from shorts or incoming static voltages.

The maximum value of count (C) is limited by the single precision integer math of the computer and is 65535 in decimal. In keeping with the conventions used in the older LPV-2 receiver, the count number is formatted before it is sent to the serial output as $N_1 N_2 N_3 N_4 . N_5$. Thus, an internal count value of 10,000 is transmitted to the serial output as 1000.0. In similar fashion, the count is formatted before displayed on the front panel of the receiver as $N_1 N_2 N_3 N_4$. This value is rounded up one if the N_5 digit is equal to 5 or greater. Thus, an internal count value of 10,000 is displayed as 1000.

With the jumper on the 0 to 10 volt setting on the main board for analog output A1, each integer count value is equal to 0.1mv output. Thus, an internal count of 10,000 is read as 1.000 volts on the A1 output. The A1 output has a 10X multiplier that can be turned on using either the 4-button interface or the PC control program. This would increase the 1.000 volt output given in the previous example to 10.000 volts. Using this setting would make the A1 output operate in similar fashion to the LPV-2. Since the analog output is controlled by a 12-bit D/A converter, only 4095 voltage levels are possible. Each ADU of the converter is equal to 2.44mv if the 0 to 10 volt jumper is set and equal to 1.22mv if the 0 to 5 volt jumper is set. In the conversion from count to ADU to set the D/A converter, the value of ADU is rounded up or down to more accurately represent the true value of count.

The calculated range of extinction (Bscat) in units of km^{-1} is 0.0000 to 6.5535. The numbers are formatted this way and transmitted on the serial output. For the front panel display, the value of extinction is rounded to the nearest 0.001 and only Bscat to three decimal places is shown.

With the jumper on the 0 to 10 volt setting on the main board for analog output A1, an extinction value of 1.0000 km^{-1} is equal to 1.000 volts. An extinction value of 0.0100 km^{-1} (Rayleigh) is equal to 0.0100 volts which may be difficult to measure accurately considering the 2.44 mv ADU step resolution and limitation in the users analog data logger. It may be necessary to use the 10X multiplier feature to raise this level to 0.100 volts.

The calculated limits of visual range (VR) in units of km is 0.6 to 391.2 assuming that the visual range constant is set to the default value of 3.912. The numbers are formatted this way and transmitted on the serial output. This formatting is also used on the front panel display.

With the jumper on the 0 to 10 volt setting on the main board for analog output A1, a visual range value of 391.2 km is equal to 3.912 volts. This assumes that the multiplier for the A1 output is set for 1X which is the default value.

Like the transmitter projector, the receiver computer has available a cycle and integration timer with time set by its own real time clock with battery backup. Both the transmitter and receiver timers are reset simultaneously, so that when the lamp turns on at the transmitter the computer starts a reading, with the selected integration time. The possible cycle times are the same as the transmitter's, which are 20 minutes, 1, 2 and 4 hours and continuous. Similar to but not equal to the transmitter, the receiver integration times are set shorter to prevent differential drifting of the separate crystal clocks from sliding the receiver integration time out of the transmitter integration time window. The receiver integration times are selectable from 1 to 60 minutes in integer steps of 1 minute

3.5 Calculations for Extinction, Visual Range and Std. Deviation

The receiver computer is able to calculate directly the extinction (Bscat) and visual range (VR) values. In order to do so, certain constants needed for the calculation can to be entered using either the PC control program or the 4-button interface menu. These constants include: the

working path length in meters, the lamp calibration number calculated during the calibration procedure and the visual range constant.

Calculation for extinction, Bscat:

$$B_{scat} = \frac{\ln(\text{count} / \text{lcn})}{\text{path}}$$

where

count = internal raw instrument value
 lcn = lamp calibration number
 path = path length from receiver to transmitter in meters.

Calculation for visual range, VR:

$$VR = \text{vrc} / B_{scat}$$

where

vrc = visual range constant (equal to 3.912 for 2% contrast or 3.000 for 5%)

Calculation for standard deviation, SD:

$$SD = \sqrt{\frac{\sum(\text{count}(I) - \text{count})^2}{\text{Integ}}}$$

where

count(I) = the count for each 1-minute integration
 count = the average of all count(I) values
 Integ = the number of 1-minute integrations making up the total reading.

3.6 Serial Output Data

The serial interface consist of RX, TX and ground using a standard 9-pin sub-D male connector on the rear panel of the receiver computer. Serial interface protocol is 9600 baud, 8 data bits, no parity and 1 stop bit. A serial data logger can be used to capture data or the free PC control program from Optec can used.

The serial output consists of the following information on one line ended by a carriage return and line feed:

| C | B | VR | N | SD | DATE | TIME |
|----------------|-----------------|----------------|-------------|----------------|-----------------|-------------------------|
| <i>NNNN.N_</i> | <i>_N.NNNN_</i> | <i>_NNN.N_</i> | <i>_NN_</i> | <i>_NNN.N_</i> | <i>_YYMMDD_</i> | <i>_HHMM_CR/L F</i> |

C= *NNNN.N* B= *N.NNNN* VR= *NNN.N* N= *NN* SD= *NNN.N* DATE= *YYMMDD* TIME= *HHMM*

where,

- C the mean of the raw counts and has no units
- B the extinction in units of km^{-1}
- VR the visual range in units of km
- N the number of 1 min. integrations
- SD the standard deviation of raw counts C.
- DATE the year, month and day
- TIME the hour and minute.

SECTION 4.0

TRANSMITTER - OPERATING PROCEDURES

Connect the input power cable to the input connector. If a cable is customer made, pin 2 is for the positive 12-volt terminal and pin 3 of the connector is for the negative (return) 12 volt terminal. Use 18 or 16 AWG stranded wire for making the input power cable to minimize power losses.

Reversing the voltage polarity to the input will result in damage to the unit. Exceeding 17 volts input voltage may also result in damage to the unit.

The flip mirror control is located on the left side of the projector unit. Turn this control clockwise until the stop is reached for siting the instrument on the receiver unit. While viewing through the focusing eyepiece, center the receiver telescope (or shelter if sufficiently far away) in the center of the circle. The center circle represents the area of the projected cone of light that is used in the lamp feedback control. The outer circle is the outside limit of the 1-degree cone of light, which is projected. While in the viewing mode, a few bars of "On a Clear Day" will play and repeat. With the lamp on and the unit in operation, a chirping sound is played when the unit is in the viewing mode. Both of these are audio reminders to return the flip mirror to the open position when viewing is finished.

The telescope is prefocused at the factory and further adjustment should be unnecessary. If the view through the projector is out of focus, loosen the front objective lens mount (slotted screw near the front of the telescope) and reposition the objective lens mount for best focus. **IMPORTANT:** This adjustment must be made before calibration. The unit will have to be recalibrated if the objective lens is repositioned. In any case, do not reposition the focusing eyepiece as this will cause a loss of alignment of the reticle to the light cone.

4.1 The 2-Button Interface

The transmitter is programmed with the use of two momentary pushbuttons labeled MODE and SELECT with the settings and prompts viewable on a 4-character display. See Figure 4-1 for a view of these controls.

When the unit is in a cycle mode and running with the lamp not on, the settings menu can be brought up by holding down the MODE key until a prompt is received. If the unit is in running continuously or anytime when the lamp is on, it can be interrupted by holding both the SELECT and MODE key down together until the ready prompt is displayed. See Figure 4-2 for a flow diagram of the settings menu.

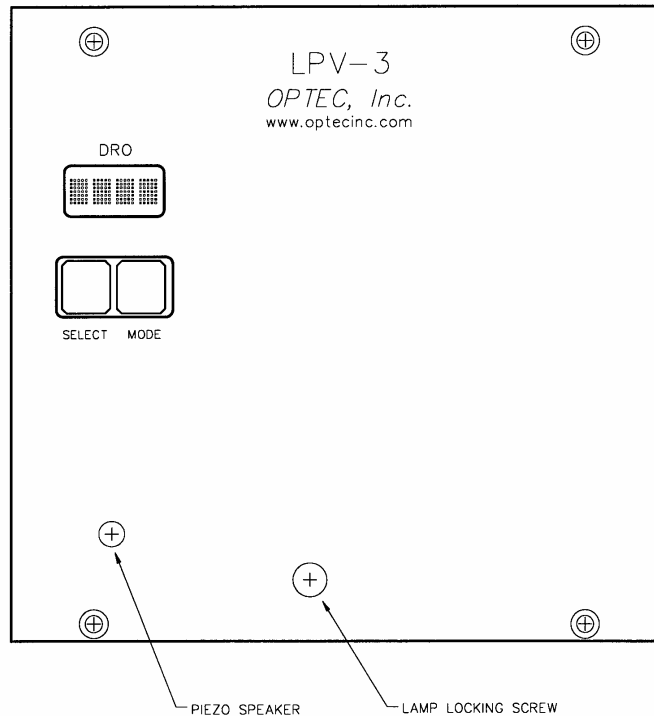

Figure 4-1. View of Transmitter Control Unit

INTG

This selection allows for changing the integration time which is the time that the lamp is on. Possible selections are: 2, 16, 32 and 64 minutes. These integration times are the same as was available with the LPV-2 transmitter.

CYCL

The available cycle times are: 20 minutes, 1 hour, 2 hours, 4 hours and CONTinuous. This is the time the unit is waiting until the beginning of a new integration. In the case of CONT, the unit will always be running with the lamp and chopper powered as long as suitable power is available. Most error checking is disabled in the CONT mode except when the lamp burns out or the chopper motor fails. An error code of ER=5 will be displayed in such a circumstance.

TEST

Pressing the SELECT button with TEST displayed will turn on the chopper motor and lamp for testing purposes. The unit will remain running until the MODE or SELECT button is pressed again. The integration times and cycle times are not interfered with.

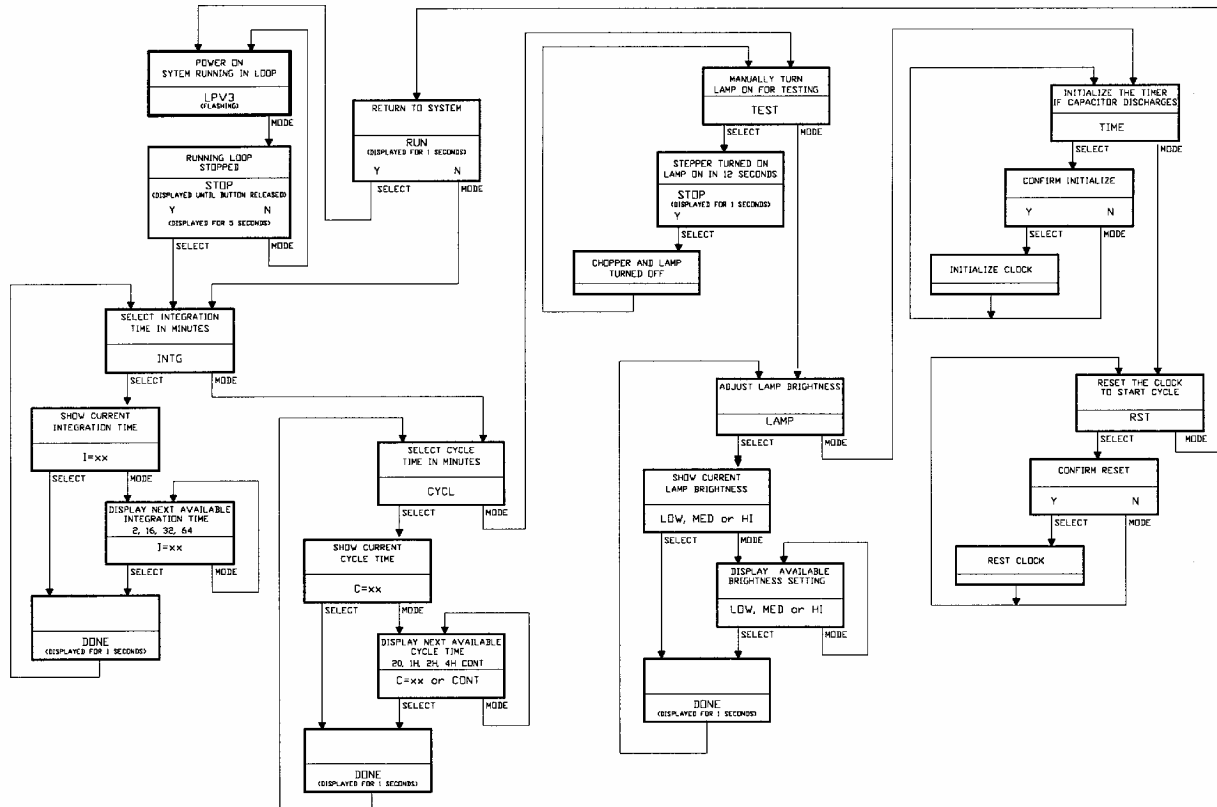

Figure 4-2. Menu Flow Diagram

LAMP

This selection allows for a choice of lamp power. The possible selections are LOW, MED and HI. For most situations, the MED selection is recommend which relates to an effective operating voltage of 6.0 going to the lamp.

TIME

If the DS1302 real time clock chip ever runs the 1 Farad capacitor down, it will loose its initialization settings. This selection only needs to be done if an error code of ER=4 is observed on the display. The unit should be left plugged into a power source for a couple of hours to recharge the capacitor. Use the RST menu selection to start the clock at the proper time.

RST

With this displayed, pressing the SELECT button twice will start the cycle clock and an integration at this point in time. Normally, the RST is selected to start the instrument running approximately one minute before the receiver will begin an integration.

4.2 Troubleshooting and Error Codes

| | |
|--------|---|
| ER = 1 | Supply voltage is less than 10.6 volts |
| ER = 2 | Maximum safe power to the lamp has been exceeded. |
| ER = 3 | No zero cross signal detected. Chopper failure. |
| ER = 4 | Real Time Chip has lost power and needs to be initialized |
| ER = 5 | Temperature of circuit board has exceeded 45° C |

Table 4-1 . Summary of Error Codes

ER=1

This usually indicates that the supply voltage from a battery is failing and the battery needs to be recharged.

ER=2

Error 2 indicates the lamp needs replacing. Even if not yet burned out, as the lamp ages the glass envelope usually darkens and the filament loses material. With less efficiency and to keep the output constant, more power must be delivered to the lamp. With the error code, the maximum safe power has been exceeded and the lamp needs to be replaced.

ER=3

If the chopper motor fails, no signal will be detected by the photodarlington. Without this signal, the unit cannot operate properly and will display this error code. Check the chopper for proper operation.

ER=4

If the unit has been sitting for a long period of time without power, the real time clock chip will run down the 1 Farad capacitor. With the power turned back on, use the 2-button interface to invoke the TIME command. This will reinitialize the timer chip. Leave the unit on for a couple of hours to full charge the capacitor. A fully charged capacitor should operate the timer in excess of 45 days. A RST command will also have to be done to synchronize the transmitter with the receiver.

ER=5

In case the internal temperature of the unit exceeds 45° C, the unit will not turn the lamp or chopper motor on. This feature is disabled if the unit is powered in continuous mode. Excessive heat may cause damage to the optical and electronic components. This feature insures that the 14 watts of the lamp and 4 watt of the stepper more do not add to the heat budget.

SECTION 5.0

RECEIVER - OPERATING PROCEDURES

Insert the photometer head into the rear port of the telescope and secure by tightening the knurled plastic knob. Flip the mirror of the photometer head to the viewing position (fully clockwise until it stops) and then focus the telescope by rotating the objective lens cell. Make sure the pan head screw near the front is loose before attempting to focus. After proper focusing, secure the pan head screw but do not over tighten it. Unlike the transmitter projector telescope, refocusing the receiver telescope after calibration does not affect the calibration constant.

While viewing through the focusing eyepiece of the photometer head, maneuver the telescope until the image of the transmitter is centered in the small ring of the reticle. If the transmitter's image drifts by more than 1/2 radius of the small ring from the center, errors in extinction could occur during periods of high turbulence because of light falling off the edge of the detector. Return the flip mirror to the measuring position by turning the knob counter clockwise until it stops.

Plug the cable from the photometer head into the port labeled "PHOTOMETER" on the rear panel of the computer enclosure. Connect the 13.8V power to the port labeled "13.8V DC" using the cable provided. If the cable is customer made, pin 2 is for the positive 13.8-volt terminal and pin 3 of the connector is for the negative (return) 13.8-volt terminal. Use 18 or 16 AWG stranded wire for making the input power cable.

Reversing the voltage polarity to the input will result in tripping the internal resettable fuse which is located on the inside circuit board. If activated by the reversed power connection or the unlikely event of an internal short, the device will go into a high impedance state and stay there until the fault condition is corrected.

The data acquisition and reduction computer is self-starting and requires no user input except for the proper settings and input of the operating constants. To reset the computer, the power must be shut off for about 1 second.

5.1 Front Panel Display



Figure 5-1. Receive Front Panel Vacuum Fluorescent Display

C=0293

Raw instrument reading normally referred to as count. If several 1-minute integrations were specified, this number would be the average of all the values. This number is the same as the serial output value rounded to the nearest unit value. Range of values are 0000 to 6553.

S=00

This is the standard deviation of the count values. If readings consisting of only one 1-minute integration are specified, this value defaults to 00. This number is the same as the serial output value rounded to the nearest unit value. Range of values are 00 to 25.

B=0.338

The value of extinction (Bscat) in units of km^{-1} is shown here. This number is the same as the serial output value rounded to the nearest one-thousandth. Range of values are 0.000 to 6.553.

STOP

Pressing the button under this word will stop the data acquisition program and start the menu configuration program. Follow the displayed dialogs to enter changes in constants or other operating parameters.

III 01

During integration, the time bar will slowly lengthen until the 1-minute integration is complete. The number on the right shows which integration is in process and will reset to 1 once the total reading is complete. Range of values for the integration counter is 01 to 60.

VR=011.5

This is the visual range in units of km. The number displayed is the same number sent to the serial output. Range of values possible are 000.0 to 999.9. A legitimate range of values would be 000.6 to 391.2 if the readings and constants were correct.

5.2 4-Button Interface

The user has the ability to change all of the constants and most of the operating parameters except the setting the clock with the 4-button interface. The top line usually displays the value to be modified and the second line displays the functions of the button directly underneath the command word. To return to the data acquisition program after modifications are complete, press the button under the RUN word. The user will then have the option to start the data acquisition program with out resetting the cycle timer by pressing the button under YES or initialize the cycle timer by pressing the button under RESET.

GAIN

Gain is adjustable from 1 to 64 by multiples of 2. Adjust GAIN to the highest value without saturating the A/D converter. When the A/D converter samples a signal outside its input voltage limits, a beep will sound. The rate of beeping is an indication of much saturation of the A/D there is. Decrease the GAIN until the beeping stops. This adjustment should be made with the transmitter during a time of high turbulence and low extinction.

The value displayed in the upper right corner of the front panel display during the GAIN adjustment is the DC background value in ADU units. The range of values is 0 to 1023 and can be considered close to the voltage in units of millivolts. Thus, a value of 800 would be close to the threshold value of 8.00 volts, which would be close to the saturation point for the electrometer amplifier. If the DC value is too high, then steps need to be taken to reduce the background brightness or some data will be lost.

CAL

The lamp calibration number is entered here for when a new lamp is installed. To rapidly change the current value to the new value, press the button under the 20X and then press the button under the + or – symbol. The lamp calibration value will then increment in units of 20.

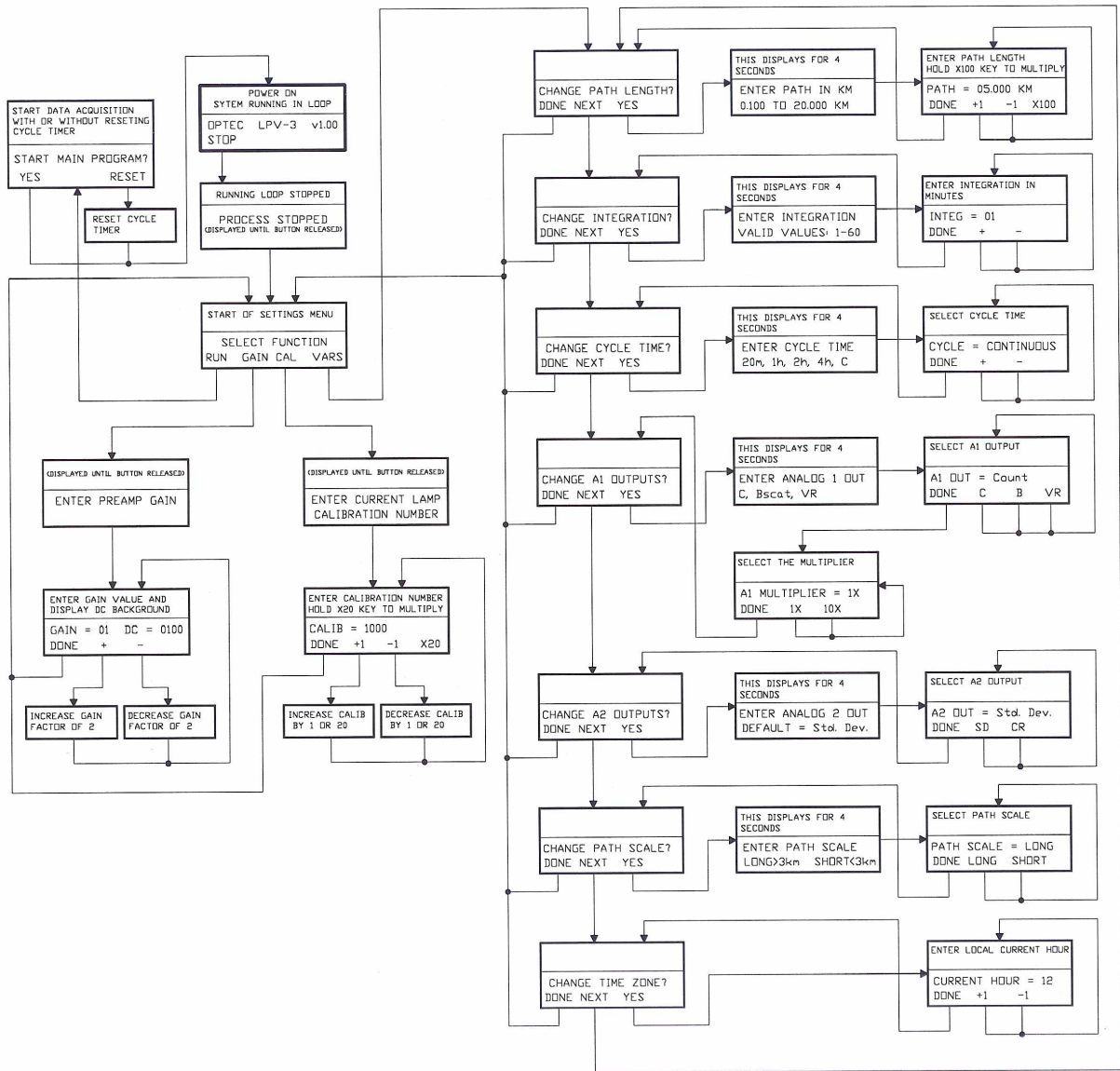

Figure 5-2. Receiver Menu Flow Diagram

VARS

Pressing the button under VARS brings up a larger sub-menu for changing more of the constants and operating parameters not commonly accessed. The user can move forward in this circular menu by pressing NEXT or exit the menu by pressing DONE or change the selected parameter by pressing YES.

CHANGE PATH LENGTH

Change working path length as measured from front of receiver telescope to front of transmitter telescope in units of meters. Round off measured distance to the nearest meter. This distance is important and should be measured with a laser range finder for greatest accuracy. To move quickly to the desired path, press the button under the 100X while pressing the button under the + or -

button. This will change the current path by units of 100 meters. Press the button under DONE to return to VARS menu.

CHANGE INTEGRATION

Enter the desired integration time in units of minutes. Press the button under the + or – symbols to increment the integration counter up or down. Permitted values are from 1 to 60. Press the button under DONE to return to the VARS menu.

CHANGE CYCLE TIME

The valid cycle times are 20 minutes, 1 hour, 2 hour, 4 hours and continuous running. Press the button under the + or – symbols to change to the desired cycle time. This cycle time should match the selected cycle time for the transmitter. When exiting the menu program, the user will have the choice to RESET the cycle timer. Pressing this key will start cycle timer and a reading will begin immediately. Normally, the RESET button is pressed a couple of minutes after the transmitter lamp has turned on in order for both the transmitter and lock in amp of the receiver to stabilize before a reading is started. Press the button under DONE to return to the VARS menu.

CHANGE A1 OUTPUTS

For users wishing to use the analog outputs for data collection, select the desired output for A1 using this option. The Count (C), Bscat (B) or Visual Range (VR) can be selected by pressing the button under the desired output. Once the output is selected, the user has the option to multiply the analog voltage by a factor of 10. This would be necessary if Bscat was selected and expected the extinction values would be near Rayleigh. See Section 3-4 for conversion from voltage to selected output value.

CHANGE A2 OUTPUTS

Either the standard deviation (SD) of the count values or the count (CR) for each 1-minute integration can be selected for analog output to A2. Press the button under the desired output value. The CR output is normally for a chart recorder, which is considered largely obsolete, but it still provided for backward compatible with the LPV-2 receiver model. Press the button under DONE to return to the VARS menu.

CHANGE PATH SCALE

This allows for an internal change in the computation of the count value and is not a change in the gain setting. For working path lengths longer than 3 km, press the button under the LONG word. For working path lengths shorter than 3 km, press the button under the SHORT word. The count value is divided by a factor of 4 when the SHORT path scale is selected. Press the button under DONE to return to the VARS menu.

CHANGE TIME ZONE

Normally, the receiver clock is set by the PC control program to whatever local time the PC is set to. This may not correspond to the correct time at where the instrument is located and the field installer may not have a computer to correct the time. This option allows the user to change the hour value to match the local time. Press the button under the +1 or –1 symbols to change the receive time hour up or down. Press the button under DONE to return to the VARS menu.

At this point, the VARS menu returns to CHANGE PATH LENGTH if the NEXT key is pressed.

SECTION 6.0

CALIBRATION PROCEDURES

Calibration determines the raw reading of the transmitter that would be measured by the receiver if the optical sight path between the two units allowed 100% transmission, a vacuum like condition. The LPV transmissometer must be calibrated as a unit. Each lamp will have its own calibration number for use with a specific transmissometer system. No component of the system, including lamps, may be interchanged with another transmissometer without re-calibration. The LPV transmissometer may be calibrated using the two methods outlined below.

6.1 ND FILTER METHOD

The Model LPV transmissometer is calibrated by a technique that negates the effect of the atmosphere. The calibration ND (neutral density) method is performed by moving the transmitter and receiver to a site which allows for a calibration path length between 0.25 and 0.50 km. This method assumes that the atmosphere is very clean with average extinctions of 0.01 to 0.06 km^{-1} and the air in the site path is well mixed. The transmission of the atmosphere at these distances is very close to 100% and can be ignored for the calculation of the calibration constant. See Table 6-1. A ND filter with transmission of approximately 1% is inserted into the photometer head of the receiver telescope. The exact transmission of this filter is measured at Optec and is indicated on the filter. The purpose of this filter is to attenuate the light amplitude by a known amount to keep the detector electrometer from saturating at these close distances.

The raw instrument readings (Count) taken from the front panel display at this distance is then scaled to the working path length taking into account changes in receiver gain, shelter window transmissions and the ND filter transmission. The result is the calibration number, which is entered into the receiver computer menu program by selecting CAL.

The calibration distance must be chosen as carefully as the working path length. Similar to the working path length, a site high off the ground to avoid thermal effects, away from smoke stacks, dirt roads or other sources of airborne particles and accessible by vehicle is definitely preferred. In picking the original working path site, the calibration path should be kept in mind. It is occasionally possible to select a site for the receiver that allows a clear view of a desirable calibration path as well. Moving the transmitter to a closer position is far easier and safer than moving the receiver unit.

Once the calibration site has been selected, the path length must be measured to an accuracy of 0.1%. This is usually only possible with a laser range finder which can determine distance to about 1 centimeter or better. A measuring tape is usable only on paths over a flat ground surface. It is possible to avoid the thermal effects of being so near the ground by doing the calibration an hour or two after sunrise or before sunset or on cloudy days. If the calibration path must be near the ground, a site off the road and over grass is preferred.

A 0.3 km calibration path length is recommended, however any path length from 0.25 to 0.50 km will work nearly as well. At 0.3 km the effect of atmospheric extinction is negligible usually being less than 0.05 km^{-1} (1.5% or less transmission drop) at most Western sites in the United States. In addition, this path length will give a high signal at a low gain setting with the supplied calibration ND filter.

| Path Length (km) | Extinction km^{-1} | | | | | | |
|---------------------|-----------------------------|------|------|------|------|------|------|
| | .01 | .02 | .03 | .04 | 0.5 | .06 | .10 |
| 0.10 | .999 | .998 | .997 | .996 | .995 | .994 | .990 |
| 0.20 | .998 | .996 | .994 | .992 | .990 | .988 | .980 |
| 0.30* | .997 | .994 | .991 | .988 | .985 | .982 | .970 |
| 0.40 | .996 | .992 | .988 | .984 | .980 | .976 | .961 |
| 0.50 | .995 | .990 | .985 | .980 | .975 | .970 | .951 |
| 0.60 | .994 | .988 | .982 | .976 | .970 | .965 | .942 |

* ideal calibration path length for instruments used at Western sites.

Table 6-1. Atmospheric Transmittances for Various Calibration Path Lengths and Extinction Values.

In order to prevent the transmitter from saturating the photometer electronics at the short calibration distance, a precision ND filter is placed in the photometer head of receiver telescope. This filter precisely reduces the incoming light from the transmitter by a factor of approximately 100 (exact transmission is indicated on the filter and is within the range of 1 to 2%). Set the GAIN value of the receiver until a reading around 700 for count is obtained.

Placing the transmitter in the TEST mode will run the transmitter continuously until switched off. The internal clock with backup will not be affected by the TEST mode but should cycle the unit properly after calibration without resetting the clock. Since the low battery circuitry will be disabled, it is up to the user to make sure that an adequate supply voltage is available during the calibration procedure.

At least 10 consecutive 1-minute integrations should be recorded. Typically, the scatter of the readings should not exceed ± 3 from the average value, which as mentioned previously should be around 700 for a 0.3 km path. Reading sequences which show scatter greater than 3 are indicative of ground thermal problems or gross changes of transparency due to rain, snow or windblown dust and a successful calibration is in doubt.

After computing the mean value, the following formula is used to calculate the calibration number:

$$\text{CAL.} = (\text{CP}/\text{WP})^2 \times (\text{WG}/\text{CG}) \times (1/\text{FT}) \times \text{WT} \times (1/\text{T}) \times \text{CR}$$

where,

| | |
|----|--|
| CP | calibration path length, 0.1000 to 0.5000km |
| WP | working path length, 0.100 to 20.00 km |
| CG | calibration gain, 1 to 64 |
| WG | working gain, 1 to 64 |
| FT | calibration filter transmission |
| WT | total shelter(s) window transmittance. If windows are used on both ends, multiply their transmittances together. Typical value for two windows is 0.902 |
| T | estimated or measured atmospheric transmittance for calibration path, 0.950 to 0.996 typical |
| CR | average of 10 readings at the calibration path |

In Appendix A, a sample calibration report form is shown. This report form may be copied and used as is or modified for the user's specific needs. Considering the complexity of the calibration, a programmed approach to calibration with trained technicians is recommended.

6.2 DIFFERENTIAL PATH METHOD

For sites where the extinction exceeds 0.10 km⁻¹, the calibration technique and calculation must take into account the atmospheric transmission over the short calibration path length. This is done by using a differential method, which in effect measures the atmospheric extinction between the calibration point and the base point. The base point or base length does not have to be the operational working path length but the process is easier if it is. Assuming that conditions are homogeneous throughout the site during calibration, a calibration number is calculated and entered into the thumb wheel switch marked CALIB. Usually all eastern United States installations must use this method of calibration. Since these sites have path lengths of less than

3 km, the receiver PATH SCALE setting of SHORT is normally used. The ND filter is not used for this method.

The calibration site/length must be chosen as carefully as the working path length. Similar to the working path length, a site high off the ground to avoid thermal effects, away from smoke stacks, dirt roads or other sources of airborne particles and accessible by vehicle is definitely preferred. In picking the original working path site, the calibration path should be kept in mind. It is occasionally possible to select a site for the receiver that allows a clear view of a desirable calibration path as well. Moving the transmitter to a closer position is far easier and safer than moving the receiver unit.

Once the calibration site has been selected, the path must be measured to an accuracy of 0.1%. This is usually only possible with a laser range finder which can determine distance to about 1 centimeter or better. A measuring tape is usable only on paths over a flat ground surface. It is possible to avoid the thermal effects of being so near the ground by doing the calibration an hour or two after sunrise or before sunset or on cloudy days. If the calibration path must be near the ground, a site off the road and over grass is preferred.

A calibration path length of 1/3 the base or working path length is recommended. For example: If the working path length were 2 km, a 0.7 km calibration path would work well. This calibration-base length ratio will result in a signal ratio of about 10/1 given a constant gain setting. Considering the lower gain setting when the instrument is moved to the calibration point and the limited dynamic range of the instrument output, a suitable signal-to-noise ratio is obtainable for the calibration calculation if this 1/3 calibration-base ratio is maintained. Of course, the actual calibration path length may have to deviate from this value depending on site constraints. A calibration path length shorter than 0.12 km (400 ft.) should be avoided due to possible saturation of the receiver photometer detector.

Selecting the TEST mode on the transmitter will run the transmitter continuously until switched off. The internal clock will not be affected by the TEST mode but should cycle the unit properly after calibration without resetting the clock. Since the low battery circuitry will be disabled, it is up to the user to make sure that an adequate supply voltage is available during the calibration procedure.

At least 10 consecutive 1-minute integrations should be recorded at each point. Start with the base or working path point, move to the calibration point and then finish by moving back to the base or working path point to complete the data taking. Typically, the scatter or standard deviation of the readings should not exceed 1% from the average value. Scatter greater than this might be indicative of ground thermal problems or gross changes of transparency due to rain, snow or windblown dust and a successful calibration is in doubt.

After computing the mean values for each point, the following formula is used to calculate the site extinction.

$$B = \frac{\ln\left(\frac{WR \times WP^2 \times CG}{CR \times CP^2 \times WG}\right)}{WP - CP}$$

where,

| | |
|----|-----------------------------|
| CP | = calibration path distance |
| WP | = base/working path |
| CR | = calibration path reading |
| WR | = base/working path reading |
| CG | = calibration gain |
| WG | = base/working gain |

once B is known, the transmission for the base or working path may be calculated using,

$$T = e^{-B \times WP}$$

and the calibration number is

$$CAL = \frac{WR}{T}$$

where WR is the raw reading at the working path distance.

A complete derivation of the equations used for the differential path method is provided in Appendix B.

SECTION 7.0

SPECIFICATIONS

7.1 GENERAL OPERATING PERFORMANCE

| | |
|-----------------------------|---|
| EXTINCTION RANGE | 0.0100 to 6.5535 km ⁻¹ |
| RESOLUTION | |
| Extinction (B) | 0.0001 km ⁻¹ |
| Visual Range (VR) | 0.1 km |
| ACCURACY | |
| Transmission | ±3% |
| Extinction | ±0.003 km ⁻¹ for 10 km working path and 0.010 nominal extinction value |
| MEASURED WAVELENGTH | |
| Filter | 550 ±2 nm, 10 ±1 nm bandwidth at ½ power points |
| OUTPUT, FRONT PANEL DISPLAY | |
| B= | Extinction (km ⁻¹) to 0.001 |
| VR= | Visual Range (km) to 0.1 km |
| C= | Instrument values from 0 to 6553 |
| σ= | Standard Deviation from 0 to 25 |
| OUTPUT, ANALOG | |
| A1 (Extinction) | 0 to 10 V, 0.010 V = 0.001 km ⁻¹ 0 to 5 V, 0.005 V = 0.001 km ⁻¹ 10X multiplier option can be applied to A1 |
| A1 (Visual Range) | 0 to 10 V, 0.010 V = 1 km 0 to 5 V, 0.005 V = 1 km 10X multiplier option can be applied to A1 |
| A1 (Calibration) | 0 to 10 V, 0.010 V = 10.0 count 0 to 5 V, 0.050 V = 10.0 count 10X multiplier option can be applied to A1 |
| A2 (Chart Rec.) | 0 to 10 V, 0.010V = 10.0 count |
| A2 (Std. Dev) | standard deviation of count samples |
| OUTPUT, SERIAL | |
| RS-232 | 9600 baud, 8 data bits, 1 stop bit, no parity |
| Outputs | Count, Bscat, Visual Range, Standard Dev., Integrating, Time and Date |
| POWER SUPPLY | |
| 12 volt auto battery | 12-14 volt Receiver, 10.6 –15 volt Transmitter |
| OPERATING TEMPERATURE | -20° TO +45° C |

7.2 TRANSMITTER SPECIFICATIONS

| | | |
|-------------------|-------------------|---|
| TELESCOPE | | |
| | Clear aperture | 58.0 mm |
| | Focal length | 350 mm |
| | Lens type | coated and cemented achromat |
| BEAM | | |
| | Diameter | 1 degree, projected cone of light |
| | Feedback Dia. | 0.17 degree as referenced to the projected cone and centered within 1 degree cone |
| | Uniformity | 5% over 1 deg. cone 1% over 0.17 deg. center cone |
| FEEDBACK FILTER | | |
| | Center Wavelength | 550 \pm 2 nm |
| | Bandwidth | 10 \pm 1 nm |
| LAMP | | |
| | Type | 6 volt, 14 watt special prefocused tungsten filament lamp mounted in machined base |
| | Regulation | constant to \pm 1.5% |
| | Life | 500 hrs. continuous at MED setting |
| CHOPPER FREQUENCY | | 78.1250 \pm .0001 Hz |
| CLOCK | | |
| | Cycle times | 20 minutes, 1, 2, and 4 hrs. |
| | Lamp-on times | 2, 16, 32, 64 minutes and continuous |
| | Freq. Tolerance | \pm 5ppm |
| POWER SUPPLY | | |
| | Voltage, input | 10.6 to 15 volts DC |
| | Power (lamp off) | 0.12 watt at 13.8 volt input |
| | Power (lamp on) | 24 watts at 13.8 volt input |
| SIZE | | |
| | Projector | 18 x 5 x 6 inches (LxWxH) |
| WEIGHT | | |
| | Projector | 5 lbs |

7.3 RECEIVER SPECIFICATIONS

| | |
|-----------------------|---|
| TELESCOPE | |
| Clear aperture | 58.0 mm |
| Focal length | 350 mm |
| Lens type | coated and cemented achromat |
| PHOTOMETER HEAD | |
| Detector | silicon PIN photodiode |
| Detector NEP | $8 \times 10^{-16} \text{ W}/\sqrt{\text{Hz}}$ |
| Active Aperture | 0.75 mm |
| Filter | 550 nm with 10 nm bandwidth |
| DETECTOR/ELECTROMETER | |
| Type | current-to-voltage |
| Gain | 4×10^9 |
| Bandwidth | DC to 500 Hz |
| Noise | 5 mv p-p DC to 500 Hz |
| Gain T-C | -200 ppm/°C |
| BANDPASS AMPLIFIER | |
| Center frequency | $78.125 \pm 0.001 \text{ Hz}$ |
| Q | 100 |
| Type | Built on LMF100 Mode 3 design with 4064 phase locked loop added for increased phase stability |
| A/D INPUT AMPLIFIER | |
| Gain | Software selectable: 1, 2, 4, 8, 16, 32, 64 |
| Bandwidth | 1 to 1000 Hz |
| Gain error | $\pm 0.024\%$ maximum |
| COMPUTER | |
| Processor | PIC18F452 from Microchip |
| Memory, bytes | 1536 RAM, 32K ROM, 256 EEPROM |
| I/O | 22 lines used |
| Real-time Clock | DS1302 with 1F capacitor backup power |
| A/D | 10 bit, 4 μ s conversion, 0 to 5.000 volts |
| D/A | 12 bit, 0-10 V output or 0-5 V output |
| OPERATING PROGRAM | Programmed in PIC BASIC PRO version 4.5 |
| INPUT CONTROLS | |
| power | On-off slide switch |
| Interface | 4 pushbuttons control all functions |

DISPLAY

| | |
|-----------------------|--------------------------------|
| Type | vacuum-fluorescent |
| Input | Serial ASCII data at 9600 baud |
| Operating Temperature | -20° to 70° C |
| Humidity | 0 to 80% RH non-condensing |

POWER SUPPLY

| | |
|-----------------|--|
| Input voltage | 12- 14 V DC, reverse voltage protected |
| Input current | 400 ma at 13.8V DC input voltage |
| Output voltages | +5, +15, -15 |

SIZE

| | |
|-----------------|----------------------------------|
| Telescope | 12.8 x 2.9 inches (L x Dia.) |
| Computer | 9 x 8 x 2.4 inches (L x W x H) |
| Photometer Head | 6 X 2.5 x 3.5 inches (L x W x H) |

WEIGHT

| | |
|-----------------|-------|
| Telescope | 6 lbs |
| Computer | 3 lbs |
| Photometer Head | 2 lbs |

Appendix A

LPV CALIBRATION DATA SHEET

Location: _____ Date: _____

Instrument ID: _____ Technician: _____

Weather/Comments: _____

=====

WORKING SETTINGS

Working Path (WP) _____ km Integration Time: 1 10 30 60

Working Gain (WG) _____ Cycle Time: C 20M 1H 2H 4H

A1 Setting: C B VR

A2 Setting: SD CR

Shelter Windows Transmittances (WT)

Receiver . Transmitter _____ . _____ Previous Calib. Number _____

=====

CALIBRATION SETTINGS

Calib. Path (CP) _____ km Receiver Through Glass: Y N

Calib. Gain (CG) _____ Transmitter Through Glass: Y N

ND Filter Transmission: ____ . ____ %

=====

EXTINCTION CONDITION BEFORE AND AFTER CALIBRATION

| | TIME | B _{ext} | | TIME | B _{ext} | | |
|---------|-------|------------------|-----|--------|------------------|-------|-----|
| Before: | _____ | _____ | M E | After: | _____ | _____ | M E |

(M measured or E estimated)

Atmospheric transmittance at time of calibration (T): _____

(calculate T using $e^{-(B_{ext} \times CP)}$ or use Table 6-1)

CALIBRATION READINGS

Start time: _____

(spare data area)

| | Reading | Toggle | Reading | Toggle |
|----|---------|--------|---------|--------|
| 1 | _____ | _____ | _____ | _____ |
| 2 | _____ | _____ | _____ | _____ |
| 3 | _____ | _____ | _____ | _____ |
| 4 | _____ | _____ | _____ | _____ |
| 5 | _____ | _____ | _____ | _____ |
| 6 | _____ | _____ | _____ | _____ |
| 7 | _____ | _____ | _____ | _____ |
| 8 | _____ | _____ | _____ | _____ |
| 9 | _____ | _____ | _____ | _____ |
| 10 | _____ | _____ | _____ | _____ |

Total _____

Average (CR) _____

=====

CALIBRATION NUMBER CALCULATION

$$\text{Calib. \#} \text{_____} = (\text{CP/WP})^2 \times (\text{WG/CG}) \times (1/\text{FT}) \times \text{WT} \times (1/\text{T}) \times \text{CR}$$

Note: modify WT if calibration is done through a shelter window

=====

ADDITIONAL COMMENTS

Appendix B

DIFFERENTIAL PATH CALIBRATION METHOD DERIVATION

The following is a complete derivation of the equations used in computing the calibration constant using the differential path method.

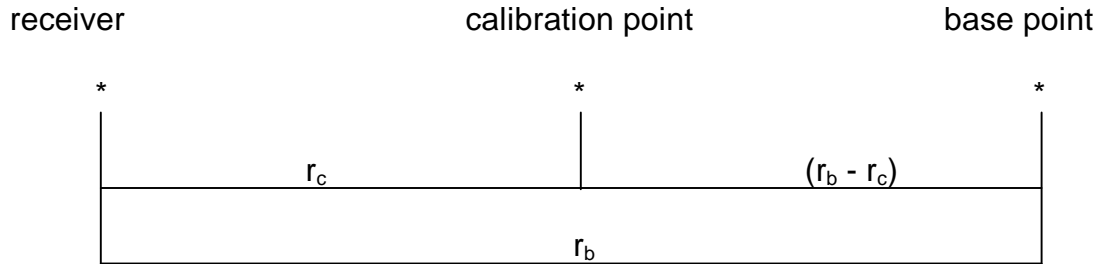

where,

- r_c = calibration path distance
- r_b = working path
- E_c = calibration path reading
- E_b = working path reading

basic principals

- 1) $T_c = e^{-Br_c}$ calibration path transmission
- 2) $T_b = e^{-Br_b}$ working path transmission
- 3) $T_{bc} = e^{-B(r_b - r_c)}$ diff. path transmission

where B is the extinction coefficient and is assumed to be constant through the entire path r_b .

The inverse of equations 1), 2), and 3) are:

- 4) $\ln T_c = -Br_c$
- 5) $\ln T_b = -Br_b$
- 6) $\ln T_{bc} = -B(r_b - r_c) = -Br_b + Br_c$

note that

$$7) \quad \ln T_{bc} = \ln T_b - \ln T_c$$

or,

$$8) \quad \ln T_{bc} = \ln \left(\frac{T_b}{T_c} \right)$$

In a vacuum, the output of the transmitter unit as a function of distance is equal to:

$$9) \quad E = \frac{I_0}{r^2}$$

where E can be considered the raw reading of the receiver unit and I_0 the transmitter output at $r = 0$.

In an atmosphere, the above equation can be written as:

$$10) \quad E = \frac{I_0}{r^2} \cdot T$$

For the calibration and working path distances, equation (10) can be written as :

$$11) \quad E_b = \frac{I_0}{r_b^2} \cdot T_b$$

$$12) \quad E_c = \frac{I_0}{r_c^2} \cdot T_c$$

where E_b and E_c are the raw readings at the working and calibration path distances.

Solve for T,

$$13) \quad T_b = \frac{E_b r_b^2}{I_0}$$

$$14) \quad T_c = \frac{E_c r_c^2}{I_0}$$

substitute (13) and (14) into equation (8),

$$15) \quad \ln T_{bc} = \ln \left| \frac{\frac{E_b r_b^2}{I_0}}{\frac{E_c r_c^2}{I_0}} \right|$$

$$16) \quad \ln T_{bc} = \ln \left(\frac{E_b r_b^2}{E_c r_c^2} \right)$$

Substitute (16) into equation (6) and solve for B.

$$17) \quad B = - \frac{\ln \left(\frac{E_b r_b^2}{E_c r_c^2} \right)}{r_b - r_c}$$

once B is known, the transmission for any path can be calculated using,

$$18) \quad T = e^{-Br}$$

and the calibration number is

$$19) \quad C = \frac{E}{T}$$

where E is the raw reading at the working path distance.

If gain adjustments are made at the calibration and working path distances, equation (17) is modified as :

$$20) \quad B = - \frac{\ln \left(\frac{E_b r_b^2 G_c}{E_c r_c^2 G_b} \right)}{r_b - r_c}$$

where G_c = calibration gain and G_b = working gain.

Appendix C

ENVIRONMENTAL ENCLOSURE

Either the transmitter projector or the receiver photometer head with the telescope can be installed in the environmental enclosure. The enclosure top plate is removable by loosening the four hand knobs visible on top of the enclosure, rotate the two knobs, which go through slots to one side free of the top plate and then swinging the top plate open. A long handle screwdriver is needed to secure either the transmitter projector or receiver telescope to the bottom of the enclosure.

The transmitter projector with integrated control is mounted in the enclosure by means of placing the L bracket within the foot mount located near the center of the enclosure and securing the two pan head machine screws. Two cable connectors are available for power - one for the projector unit and the other for the heated window option. Make sure the telescope view is not blocked by the window or stray cable.

The receiver photometer head with small telescope is mounted in the enclosure by means of placing the L bracket within the foot mount located near the center of the enclosure and securing the two pan head machine screws. Make sure the window or stray cables do not block the telescope view. Connect the available 9-pin connector to the photometer cable and the heated window, if supplied, to the 4-pin connector.

Successful operation of the transmissometer requires precise alignment of both the receiver and transmitter telescopes. Because of the critical alignment of these instruments, great care should be exercised in construction of the mount for the environment enclosures to insure that this alignment can be obtained and held even during diurnal temperature changes and wind loading. It is recommended that our permanent mounting pier (stock no. 86676) be used to hold the enclosure. Since the enclosure with instrument weighs approximately 33 lbs, the mounting plate and/or structure should be made from thick stock - 3/8 to 1/2" aluminum or steel plate.

The base of the enclosure allows for a small amount of azimuth and altitude adjustment. The maximum adjustment range for azimuth is 14° ($\pm 7^{\circ}$ from center) and 8° ($\pm 4^{\circ}$ from horizontal) for altitude. This small adjustment range requires some care in placing the pier or mounting plate in order that, once the enclosure is roughly mounted on the pier or plate, alignment can be accomplished by turning the fine adjustment screws within this limited range. See Figure C-1 for mounting and connecting details.

Clean the enclosure windows with alcohol only. Commercial window cleans usually have some kind of chemical polish which will change the transmission of the glass by an unknown amount.

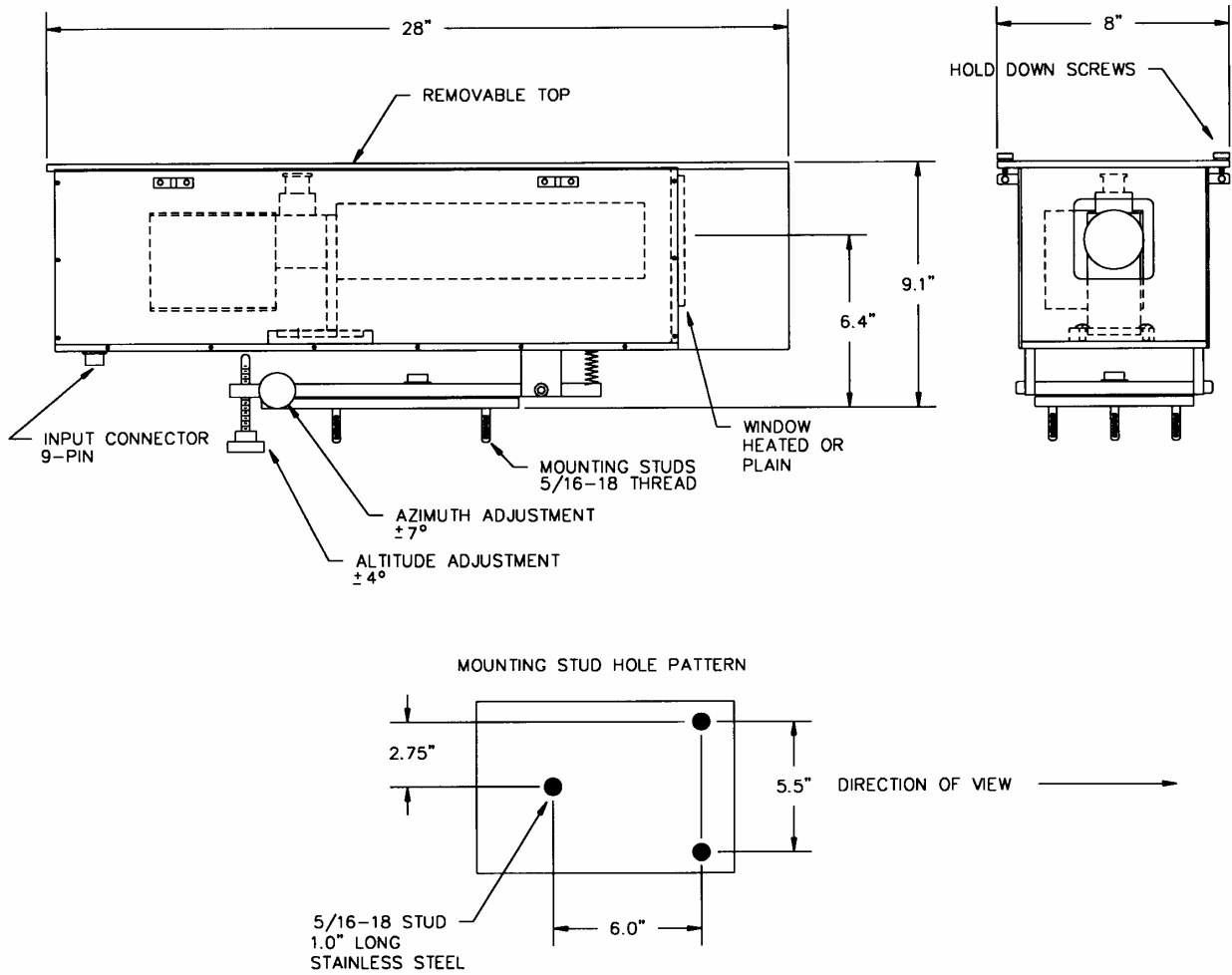

| CONNECTOR WIRING | | |
|------------------|---------------|-------------------------|
| PIN | FUNCTION | INSTRUMENT |
| 1 | -15 V | RECEIVER |
| 2 | +15 V | RECEIVER |
| 3 | SIGNAL | RECEIVER |
| 4 | NC | |
| 5 | NC | |
| 6 | SIGNAL GND. | RECEIVER |
| 7 | 13.8 V RETURN | TRANSMITTER OR RECEIVER |
| 8 | 13.8 V DC | TRANSMITTER OR RECEIVER |
| 9 | SHIELD | RECEIVER |

Figure C-1. Environmental Enclosure Details

Appendix D

13.8 VDC POWER SUPPLY

For AC installations, the 13.8 V DC power supply (Optec stock #86905) is required. This power supply measures 8 x 6 x 2 inches and will accept any of two switched inputs of 90-132 VAC 50/60Hz or 180-264VAC 50/60 Hz. The unit will supply 13.8±0.3 VDC at up to 10 amps to either the receiver or transmitter unit

Two different output connectors are available depending on distance to the receiver or transmitter. For distances up to 60 feet, connection to the 4-pin Amp circular connector is recommended. Parts for the plug with crimp terminals compatible with 16 or 18 AWG wire are included with the power supply. Connect as follows:

| | |
|-------|-----------------|
| Pin 1 | (not connected) |
| Pin 2 | +13.8 VDC |
| Pin 3 | 13.8 V return |
| Pin 4 | (not connected) |

For distances greater than 60 feet, connection to the banana jacks are recommended to limit voltage loss due to the resistance of the power cable. Use of 12 AWG wire would allow the power supply to be mounted 200 feet from the transmitter or receiver units. Of course, the wire size would have to be reduced to 18 or 16 AWG near the units to accommodate the terminals to the circular connector going into the instrument or environmental enclosure. Connect as follows:

| | |
|----------------|---------------|
| Red terminal | +13.8 VDC |
| Black terminal | 13.8 V return |

Appendix E

CONNECTOR PIN DEFINITIONS

TRANSMITTER

| PIN # | DESCRIPTION |
|-------|------------------|
| 1 | NC |
| 2 | +10.6 to 15 V DC |
| 3 | Power Return |
| 4 | NC |

4-Pin Power Input Connector

RECEIVER

| PIN # | DESCRIPTION |
|-------|----------------|
| 1 | NC |
| 2 | +12 to 14 V DC |
| 3 | Power Return |
| 4 | NC |

4-pin Power Input Connector

| PIN # | DESCRIPTION |
|-------|---------------------|
| 1 | Analog 1 Signal |
| 2 | Analog 2 Signal |
| 3 | Toggle Signal |
| 4 | Analog 1 Common |
| 5 | Analog 2 Common |
| 6 | Digital Common |
| 7 | NC |
| 8 | NC |
| 9 | Shield, Case Ground |

9-pin Output Connector

| PIN # | DESCRIPTION |
|-------|----------------------------------|
| 1 | -15.0 V |
| 2 | +15.0 V |
| 3 | Photometer Signal |
| 4 | NC |
| 5 | NC |
| 6 | Signal Common |
| 7 | 13.8 V Return (Enclosure Option) |
| 8 | 13.8 V (Enclosure Option) |
| 9 | Shield, Case Ground |

9-pin Photometer Connector

| PIN # | DESCRIPTION |
|-------|---------------------|
| 1 | Shield, Case Ground |
| 2 | TX |
| 3 | RX |
| 4 | NC |
| 5 | GND |
| 6 | NC |
| 7 | NC |
| 8 | NC |
| 9 | NC |

DB-9 RS-232 Interface Connector

Appendix F

WIRING AND CIRCUIT DIAGRAMS

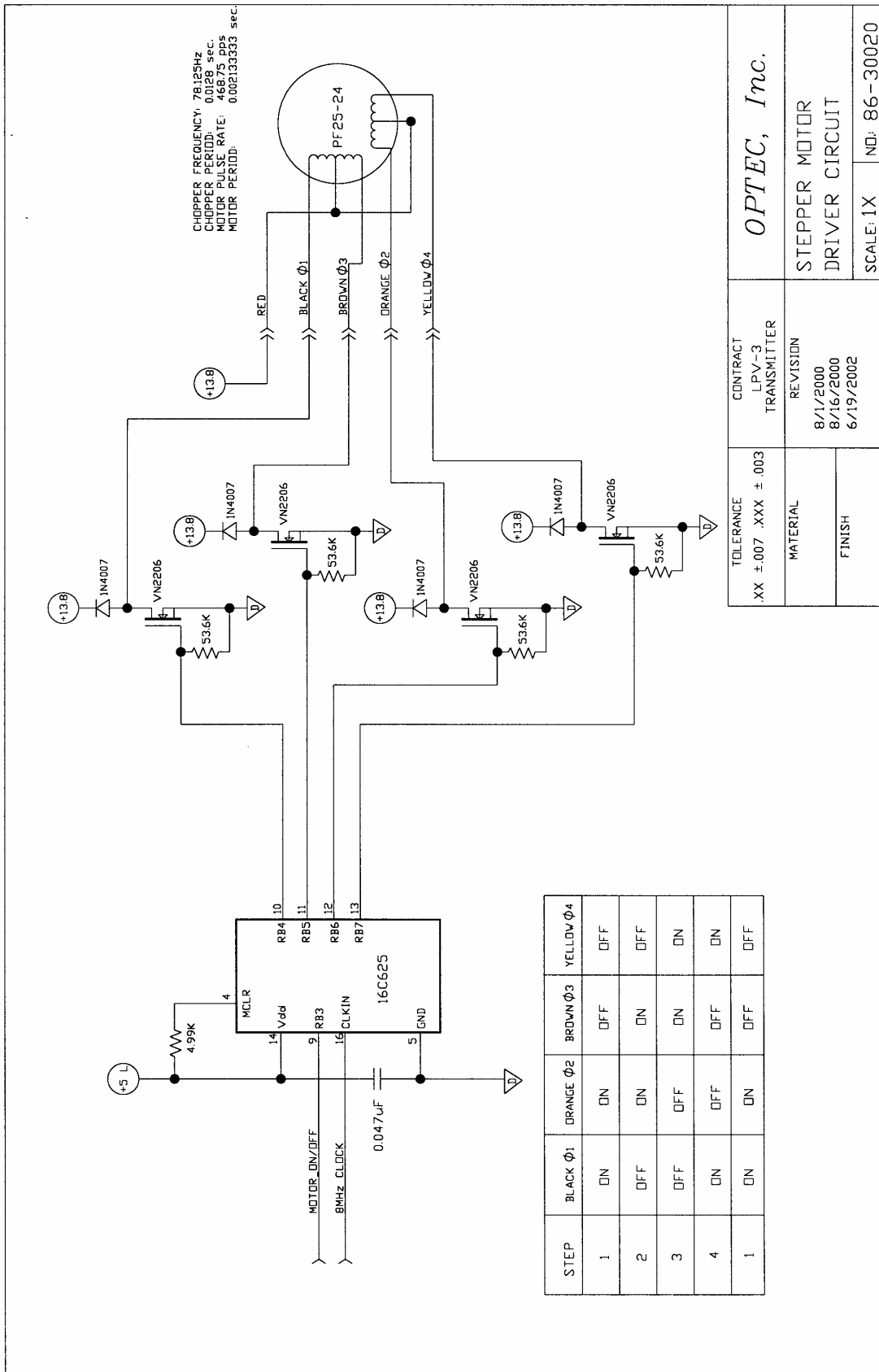

| | | | |
|-----------------------------------|--|---------------------------------|--------------|
| TOLERANCE .XX ±.007 .XXX ±.003 | CONTRACT LPV-3 TRANSMITTER | <i>OPTEC, Inc.</i> | |
| MATERIAL | REVISION 8/1/2000 8/16/2000 6/19/2002 | STEPPER MOTOR DRIVER CIRCUIT | |
| FINISH | | SCALE: 1X | ND: 86-30020 |

Figure F-3 Transmitter Stepper Motor Control Circuit Diagram.

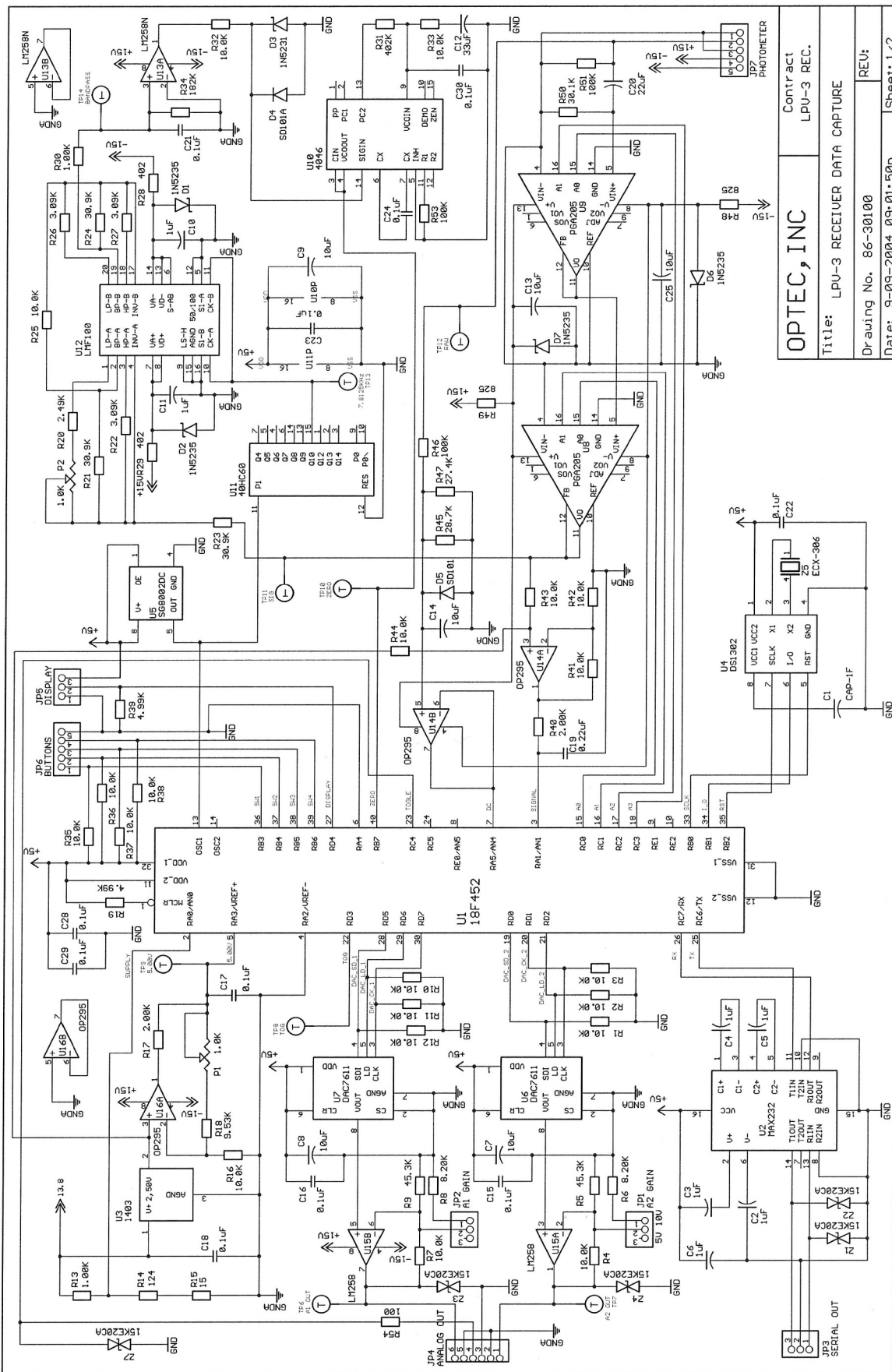
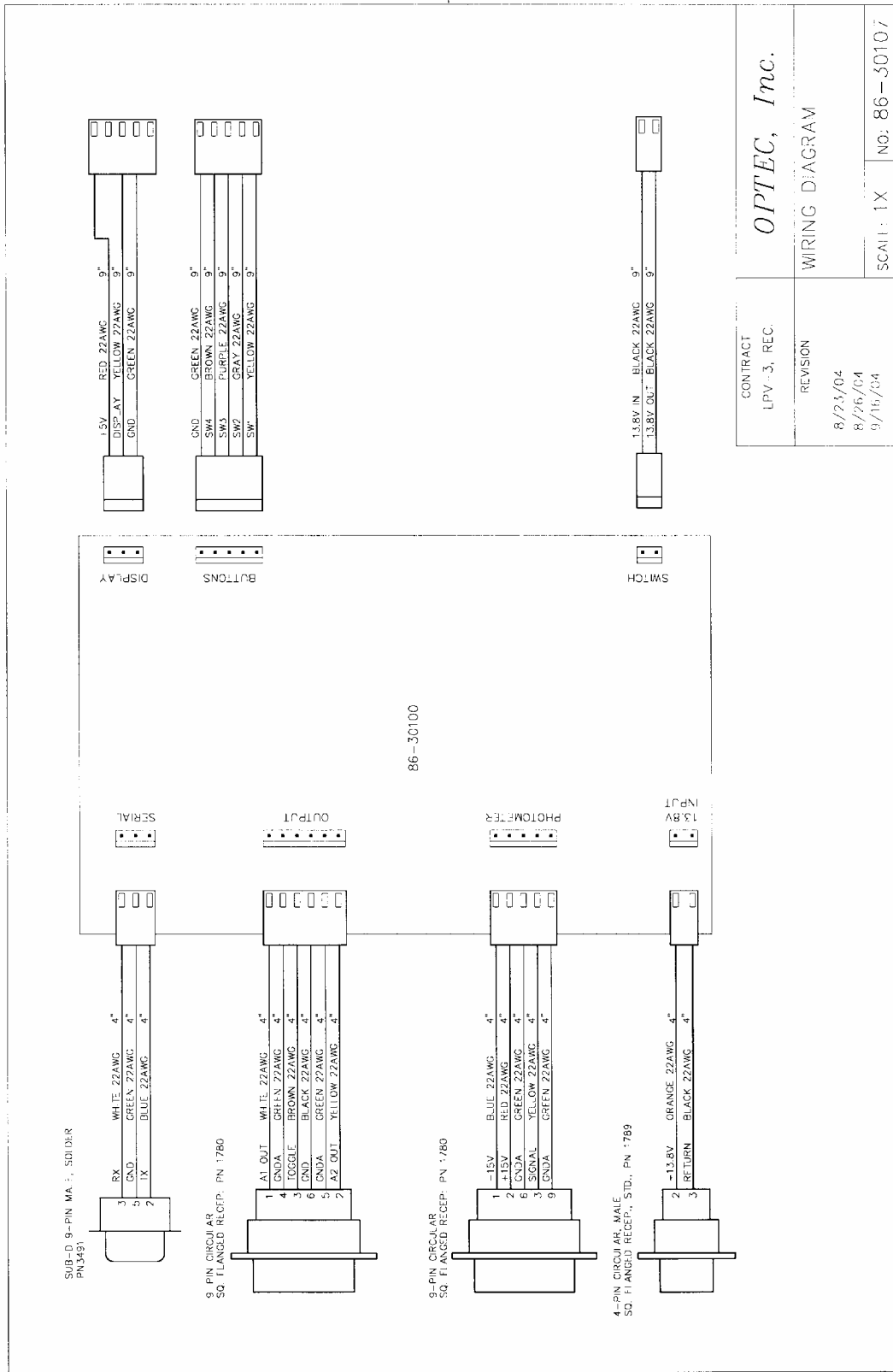

Figure F-4. Receiver Circuit Diagram.

Contract
OPTEC, INC
 LPU-3 REC.
 Title: LPU-3 RECEIVER DATA CAPTURE
 Drawing No. 86-30100
 Date: 9-09-2004 09:01:50P
 Sheet: 1/2

REV:



| | | |
|-------------------------|--------------------|--|
| CONTRACT LPV-3, REC. | OPTEC, Inc. | |
| REVISION | WIRING DIAGRAM | |
| | 8/23/04 | |
| | 8/26/04 | |
| | 9/16/04 | |
| SCALE: 1X | NO: 86-30107 | |

Figure F-6. Wiring Diagram for Receiver.

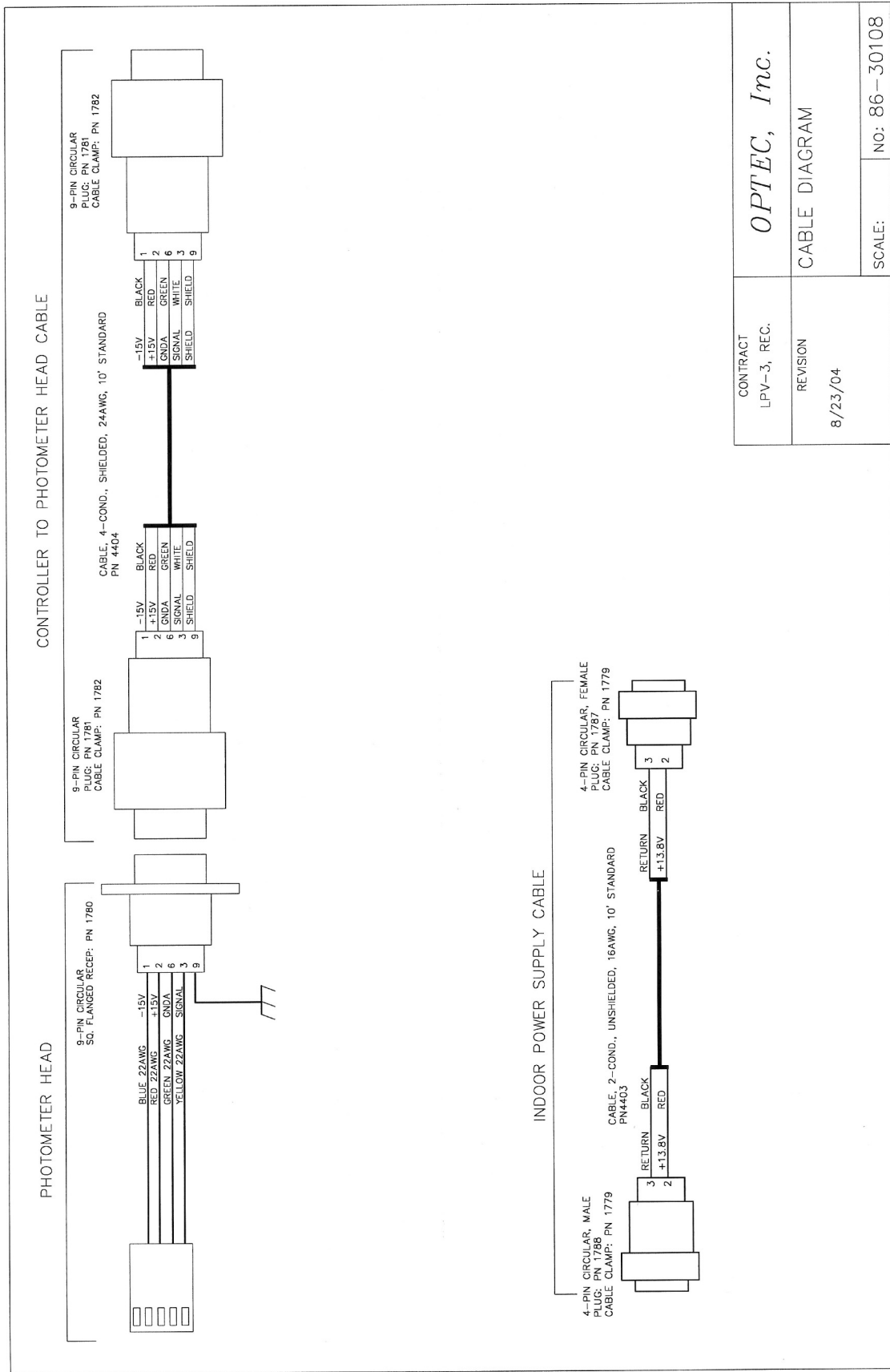

| | | |
|-------------------------|--------------------|----------|
| CONTRACT LPV-3, REC. | <i>OPTEC, Inc.</i> | |
| REVISION 8/23/04 | CABLE DIAGRAM | |
| SCALE: | NO: | 86-30108 |

Figure F-7. Receiver Cable Wiring Diagram.

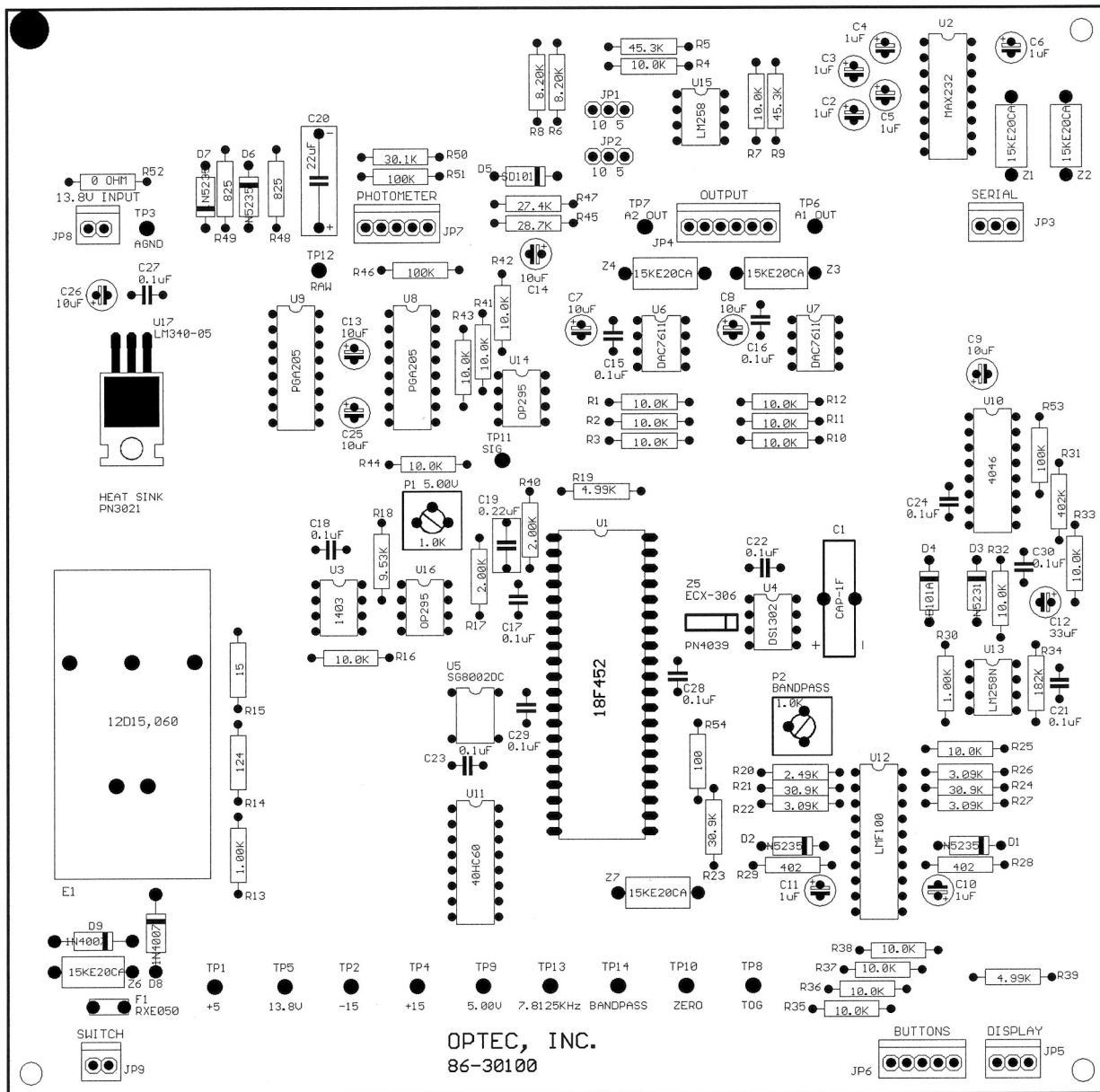

Figure F-8. Receiver Circuit Board Layout.